

IDEAL 4815



IDEAL 4850





- D** Bitte lesen Sie vor Inbetriebnahme der Maschine unbedingt diese Betriebsanleitung und beachten Sie die Sicherheitshinweise. Die Betriebsanleitung muss jederzeit verfügbar sein.
- GB** Please read these operating instructions before putting the machine into operation and observe the safety precautions. The operating instructions must always be available.
- F** Nous vous prions de lire attentivement le mode d'emploi avant d'utiliser la machine, et attirons votre attention sur les consignes de sécurité. Les instructions d'utilisation et les consignes de sécurité doivent toujours être disponibles. Les instructions d'utilisation et les consi.
- NL** Leest u voor de ingebruik name van het apparaat a.u.b. deze gebruiksaanwijzing goed door en neemt u de veiligheidsinstructies n acht. De gebruiksaanwijzing en de veiligheids-voorschriften moeten altijd binnen handbereik zijn.
- I** Per favore legga questo manuale di istruzione prima di mettere in funzione il distruggidocumenti e osservi le regole di sicurezza. Le istruzioni d'uso devono essere sempre disponibili.
- E** Le recomendamos lea las instrucciones antes de poner en funcionamiento esta máquina y cumpla las normas de seguridad. Las instrucciones de servicio y seguridad deben estar siempre disponibles.
- S** Läs igenom denna bruksanvisning innan ni startar maskinen. Var noga med säkerhetsföreskrifterna. Instruktionsmanualen måste alltid finnas tillgänglig.
- FIN** Lue nämä käyttö-ohjeet läpi ennenkuin käynnistät laitteen !
Noudata turvaohjeita. Käyttöohjeiden on oltava aina saatavilla.
- N** Lees gjennom denne bruksanvisningen før De tar i bruk maskinen
Vær oppmerksom på sikkerhetsforskriftene. Operatørmmanualen må alltid være tilgjengelig.
- PL** Proszę uważnie przeczytać instrukcję obsługi przed uruchomieniem urządzenia i stosować się do przepisów bezpieczeństwa. Instrukcje obsługi muszą być zawsze dostępne.
- RUS** Пожалуйста, прочитайте инструкцию по эксплуатации перед установкой аппарата, соблюдайте технику безопасности. Инструкция по эксплуатации должна находиться в доступном для пользователя месте.
- H** A gép üzembe helyezésé előtt figyelmesen olvassa el a kezelési utasítást és tartsa be a biztonsági előírásokat. Kezelési utasításnak mindig elérhetőnek kell lennie.
- TR** Lütfen makineyi çalıştırmadan önce bu kullanma talimatlarını dikkatli bir şekilde okuyunuz ve belirtilen güvenli k önlemlerine uyunuz. Kullanma Talimatları her zaman kullanıma hazır olmalıdır.
- DK** Før installation af maskinen bedes De venligst læse brugervejledningen og være opmærksom på sikkerhedsanvisningerne. Brugervejledningen skal altid være tilgængelig.
- CZ** Prosim přečtete si instrukce k obsluze a dodržujte bezpečnostní upozornění. Návod k obsluze musí být vždy dostupný.
- P** Por favor leiam o manual de instruções antes de colocar a máquina em operação e vejã as precauções de segurança. As instruções de operação deverão estar sempre disponíveis.
- GR** ΠΑΡΑΚΑΛΩ ΔΙΑΒΑΣΤΕ ΤΙΣ ΟΔΗΓΙΕΣ ΧΡΗΣΕΩΣ ΚΑΙ ΤΙΣ ΠΡΟΦΥΛΑΞΕΙΣ ΑΣΦΑΛΕΙΑΣ ΠΡΙΝ ΒΑΛΕΤΕ ΤΟ ΜΗΧΑΝΗΜΑ ΣΕ ΛΕΙΤΟΥΡΓΙΑ. ΟΙ ΟΔΗΓΙΕΣ ΧΡΗΣΗΣ ΠΡΕΠΕΙ ΝΑ ΕΙΝΑΙ ΠΑΝΤΑ ΔΙΑΘΕΣΙΜΕΣ.
- SLO** Prosim preberite navodila za uporabo ter upoštevajte varnostna opozorila preden zaženete napravo. Navodila naj bodo vedno pri roki.
- SK** Starostlivo si preštudujte tento návod na obsluhu pred uvedením stroja do prevádzky a najmä bezpečnostné predpisy. Držte tento návod na obsluhu na dostupnom mieste.
- EST** Palun lugege enne masina käivitamist käesolevat kasutusjuhendit ning järgige ohutusnõudeid. Kasutusjuhend peab alati käepärast olema.
- CHI** 使用機器前，請閱讀此操作指引，並留意安全守則
操作手册必須是經常可用的。
- UAE** والإمان والوقاية تعليمات ملاحظة نرجوا كما الماكينة بتشغيل البدء قبل التشغيل تعليمات قراءة نرجوا لا بد من وجود تعليمات التشغيل دائما



- D** Keine Bedienung durch Kinder!
GB Children must not operate the machine!
F Pas d'utilisation par un enfant!
NL Geen bediening door kinderen!
I Non lasciare utilizzare il tagliacarte a bambini!
E No dejar que la utilicen los niños!
S Installera maskinen utom räckhåll för barn!
FIN Asentakaa laite lasten ulottumattomiin !
N Installer maskinen utenfor rekkevidde for barn!
PL Dzieciom nie wolno obsługiwać urządzenia !
RUS Не допускайте детей к пользованию аппаратом!
H Gyerekek a gépet nem kezelhetik
TR Makinayı Çocuklar Kullanmamalıdır.
DK Må kun betjenes af voksne
CZ Stroj nesmí být obsluhován dětmi!
P As crianças não devem trabalhar com a máquina!
GR ΑΠΑΓΟΡΕΥΕΤΑΙ Η ΧΡΗΣΗ ΑΠΟ ΠΑΙΔΙΑ.
SLO Otroci ne smejo uporabljati naprave
SK So strojom nesmú pracovať deti!
EST Lapsed ei tohi masinat kasutada!
CHI 勿让儿童使用机器!
UAE يجب علي الأطفال عدم تشغيل الماكينة.



- D** Nicht unter das Messer fassen!
GB Do not reach beneath the blade!
F Ne pas passer les mains sous la lame!
NL Niet met de handen onder het mes komen!
I Non toccare la lama nella parte inferiore!
E ¡No tocar debajo de la cuchilla!
S Sträck inte in handen under kniven!
FIN Älä laita kättäsi terän alle !
N Plasser aldri hender ol. under kniven !
PL Nie wkładać rąk pod noże!
RUS Избегайте попадания рук под лезвие!
H Ne nyúljon a kés alá!
TR Elinizi bıçağın altına sokmayınız!
DK Stik ikke hænderne ind under knivbladet!
CZ Nesahejte pod ostrří nože!
P Não tocar na parte inferior da faca!
GR ΜΗΝ ΑΓΓΙΖΕΤΕ ΤΟ ΚΑΤΩ ΜΕΡΟΣ ΤΗΣ ΛΕΠΙΔΑΣ!
SLO Ne segajte z roko pod rezilo!
SK Nevkladajte ruky pod nôž!
EST Ärge pange kätt tera alla!
CHI 请勿接触刀具的下方。
UAE لا تلمس تحت السكين





- D** Messer nie lose liegen lassen!
Messer nur mit Messerwechsellvorrichtung oder im Messertransportkasten befördern!
(siehe Seite 27 und 29).
⚠ **Warnung!** Verletzungsgefahr!
- GB** Never leave the blade unattended!
Do not extract or transport the blade without protection!
(See page 27 and 29).
⚠ **Danger!** Risk of injury!
- F** Ne jamais laisser la lame sans protections !
Elle ne doit être démontée qu'à l' aide du dispositif de changement de lame (cf. page 27 et 29), ou transportée dans son étui en bois !
⚠ **Danger!** Risques de coupures !
- NL** Laat nooit de messen alleen achter.
Transporteer de messen niet zonder de houten bescherming (zie pagina 27 en 29).
⚠ **Waarschuwing!** Opgelet voor ongevallen!
- I** Non lasciare mai la lama incustodita. Non rimuovere o trasportare la lama senza protezione. (Vedi pagina 27 e 29).
⚠ **Attenzione!** Rischio di infortunio!
- E** ¡No quitar la cuchilla sin prestar atención. No desmontar no transportar la cuchilla sin protección! (vérase pág. 27 y 29)
⚠ ¡**Advertencia!** ¡Peligro de hacerse daño!
- S** Lämna aldrig maskinen obemannad. Ta inte ur eller transportera kniven utan skydd. (se sid 27 och 29).
⚠ **Skaderisk!**
- FIN** Käsittelle terää aina varoen. Älä siirrä tai kuljeta terää ilman suojaa ! (katso sivu 27 ja 29)
⚠ **Loukkaantumisen vaara !**
- N** La aldri kniven ligge ubeskyttet. Ta aldri ut kniven eller transporter den uten beskyttelse (Se side 27 og 29)
⚠ **FARE !** Muligheter for skade !
- PL** Nigdy nie pozostawiać noży bez nadzoru.
Nie wyciągać lub transportować noży bez osłon!
(zobacz strona 27 i 29).
⚠ **Ryzyko skaleczenia sie!**
- RUS** Не оставляйте открытое лезвие без присмотра! Не пытайтесь извлечь или транспортировать лезвие без специальных мер предосторожности!
(См. страницы 27 и 29)
⚠ **Соблюдайте выше перечисленные правила для избежания травм!**
- H** Soha ne hagyja a kést őrizetlenül!
Ne vegye ki vagy ne szállítsa a kést védőtok nélkül!
(Lásd 27. és 29. oldal)
⚠ **Veszély!** Sérülésveszély!
- TR** Bıçağı hiçbir zaman gözetimsiz bırakmayınız!
Bıçağı muhafazasız olarak yerinden çıkartmayınız veya taşımayınız! (Sayfa 27 ve 29'e bakınız)
⚠ **Dikkat!** Yaralanma riski!



- DK** Knivbladet må aldrig efterlades uden opsyn.
Forsøg ikke at afmontere eller transportere knivbladet uden beskyttelse! (Se side 27 og 29)
⚠ **FARE! Risiko for legemlig beskadigelse.**
- CZ** Nikdy nenechávejte nůž bez krytu.
Nikdy nevyjímejte nebo neprepravujte nůž bez ochranného krytu (viz. strany 27 a 29)
⚠ **Nebezpečí! Riskujete zranění**
- P** Deixar a faca sempre em local seguro!
Não retirar ou transportar a faca sem protecção!
(Ver pág. 27 e 29)
⚠ **Perigo! Risco de dano!**
- GR** ΜΗΝ ΑΦΗΝΕΤΕ ΤΗΝ ΛΕΠΙΔΑ ΑΝΕΠΙΤΗΡΗΤΗ!
ΜΗΝ ΑΛΛΑΖΕΤΕ Ή ΜΕΤΑΦΕΡΕΤΕ ΤΗΝ ΛΕΠΙΔΑ ΧΩΡΙΣ
ΠΡΟΦΥΛΑΞΗ (Δείτε σχετικά στις σελίδες 27 & 29)
⚠ **ΠΡΟΣΟΧΗ ! ΚΙΝΔΥΝΟΣ ΤΡΑΥΜΑΤΙΣΜΟΥ !**
- SLO** Nikoli ne puščajte rezila nazaščitenega. Nikoli ne prenašajte
rezilo brez zaščite. (glej stran 27 in 29).
⚠ **Pozor! Nevarnost poškodbe.**
- SK** Nenechávajte nôž nechránený (nezabezpečený)!
Nevyberajte alebo netransportujte nôž bez ochrany
(vid s. 27 a 29)
⚠ **! Riziko úrazu !**
- EST** Ärge jätke lõiketera kunagi järelevalveta!
Ärge pikendage ega teisaldage tera kaitseseadmeteta!
(Vt lk 27 ja 29)
⚠ **Oht! Vigastuste oht!**
- CHI** 在没人留意的情况下，请勿离开刀具。
在没有保护的情况下，请勿取出或运送刀具！（参阅第 27 和 29 页）。
⚠ 危险！可引致受伤！
- UAE** لا تترك السكين بدون اهتمام
لا تخرج أو تنقل السكين بدون حماية (انظر صفحة 27 و 29)
⚠ خطر! التعرض للآذى

IDEAL 4815 • IDEAL 4850

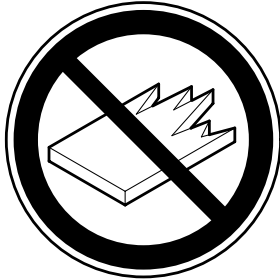

- D** Keine harten und splitternden Materialien schneiden!
- GB** Do not cut hard materials or materials which may splinter!
- F** La coupe de matériaux trop durs ou risquant des projections est interdite !
- NL** Snij geen harde materialen of materiaal dat kan splinteren!
- I** Utilizzare il tagliacarte esclusivamente per il taglio di risme di carta o materiali analoghi!
- E** ¡No cortar materiales duros o materiales que puedan astillarse!
- S** Förstör inte hårt material eller material som kan splittras!
- FIN** Asentakaa laite lasten ulottumattomiin !
- N** Ikke kutt hardt metall eller materiale som kan splintre !
- PL** Nie ciąć twardych materiałów lub materiałów, które mogą ulec odprysnięciu!
- RUS** Данный резак не предназначен для резки твердых материалов или материалов, которые могут расщепляться!
- H** Ne vágjon kemény vagy olyan anyagot, amely repedhet!
- TR** Sert veya parçalanabilecek malzemeleri kesmeyiniz!
- DK** Der må ikke skæres i hårde materialer eller i materialer, der kan splintre!
- CZ** Neřežte tvrdý materiál, při kterém mohou ustřelovat ostré úlomky!
- P** Não cortar materiais duros ou materiais que possam lascar!
- GR** ΜΗΝ ΚΟΒΕΤΕ ΣΚΛΗΡΑ ΥΛΙΚΑ Ή ΥΛΙΚΑ ΠΟΥ ΘΡΥΜΜΑΤΙΖΟΝΤΑΙ!
- SLO** Nikoli ne režite trdih materialov ali materialov, ki se lahko razcepijo.
- SK** Nerežte tvrdé materiály, alebo materiály, z ktorých môžu vystrelovať ostré úlomky.
- EST** Ärge lõigake kõvasid materjale ega materjale, mis võivad pilbasteks puruneda!
- CHI** 请勿切割坚硬或可裂成碎片物料。
- UAE** لا تقطع الأشياء الصلبة أو الأشياء التي يتطاير منها شظايا!

• Safety precautions •

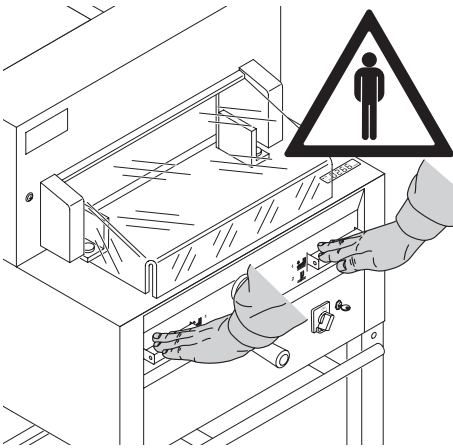

The machine is designed for cutting stacks of paper to a specified size.
This machine is constructed for "one-man operation" only!
⚠ **Warning!** Clips or similar damage the cutting blade.

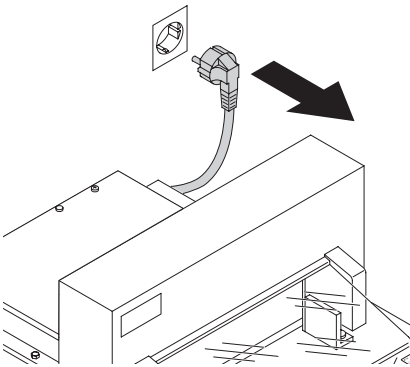

Disconnect from the mains before starting any service work or before removing the panels!

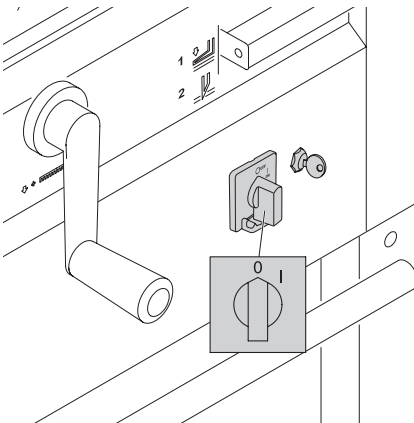

Replacement of blade and cutting stick may be performed only when the main switch is switched off!

IDEAL 4815 • IDEAL 4850

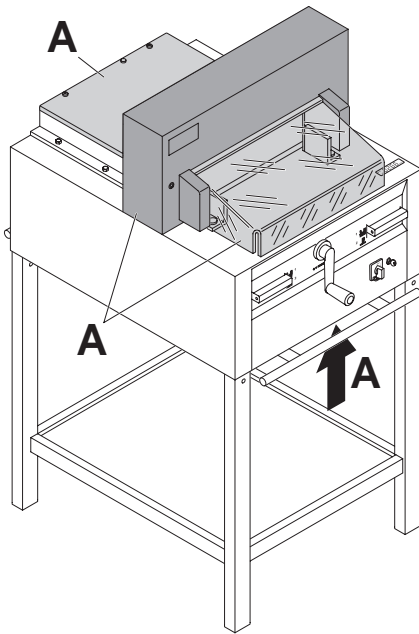

All components which could endanger the operator are covered by a guard!

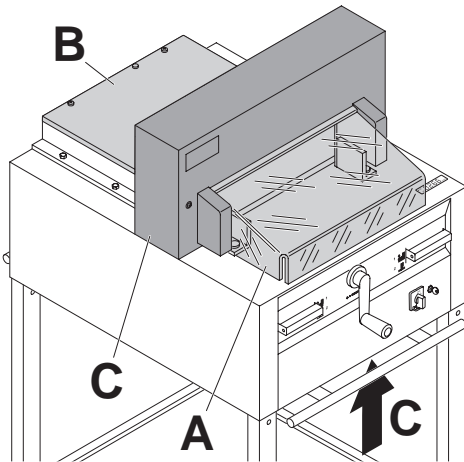

Operating the machine without safety device is forbidden!
(Front safety guard (A), rear screwed safety guard (B) and panel (C)).

• Safety precautions •

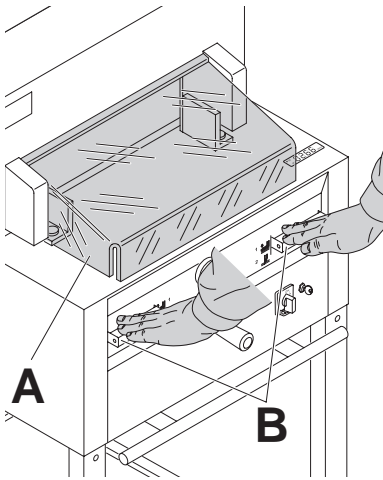

The dangerous cutting movement is safeguarded by a movable guard (A) and a safety two-handed control system! (B)

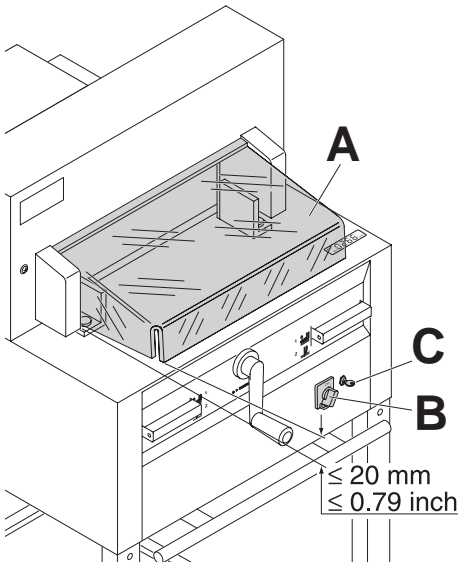

Before working with the machine and after every blade replacement the automatic cut-off function of safety guard (A), (correct if distance between cover and table is $< 20 \text{ mm}$) main switch (B) and control panel (C) must be checked.

IDEAL 4815 • IDEAL 4850

Protect mains cable against heat, oil and sharp edges!

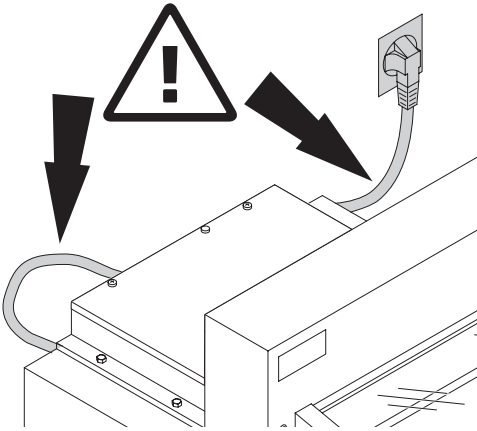

Connect the power cord to a single phase socket.

230V / 10A min
115V / 15A min

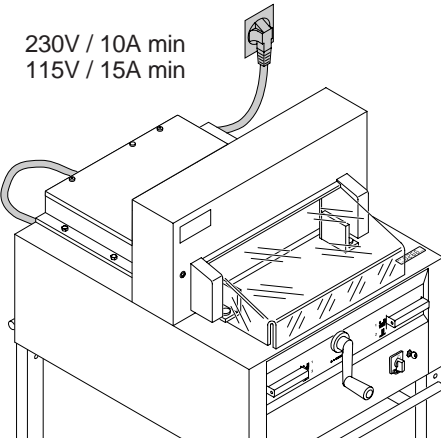

Ensure free access to mains!

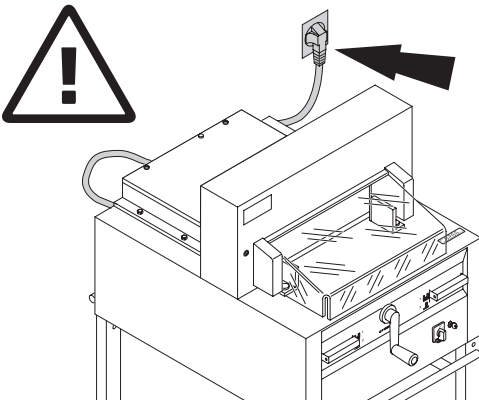

• Safety precautions •

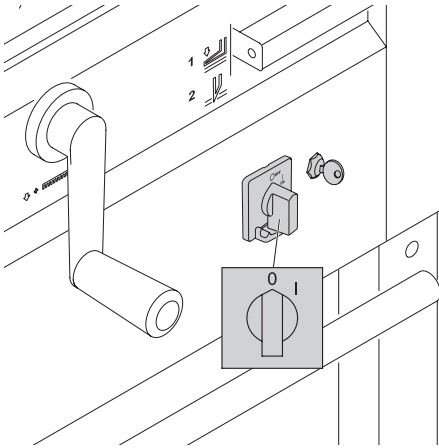

When not in use for a longer period switch off.
(Main switch to "0").

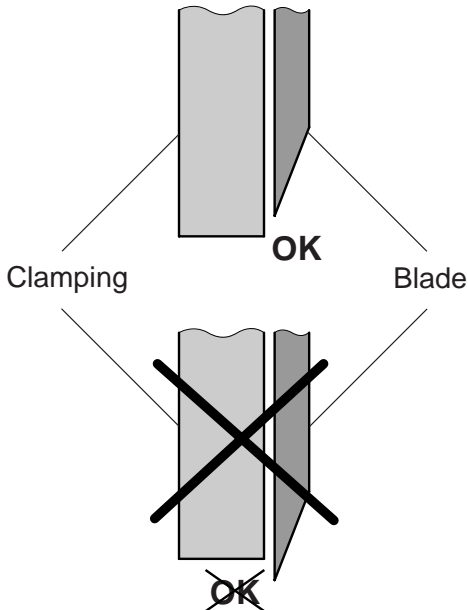

Warning by IDEAL 4815

⚠ Danger!

Blade must always be covered by the pressing bar.

IDEAL 4815 • IDEAL 4850

Remove the stand from the wooden pallet.

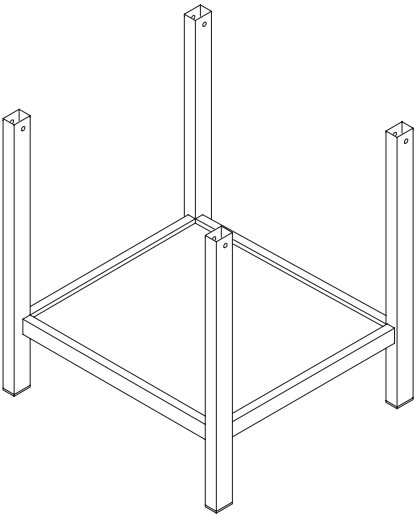

4 strong people are required to lift the machine from the pallet and place it on the stand. Secure with 4 screws (A). Put the shelf (B) on the stand. (Parts and tools are in the tool set (C)).

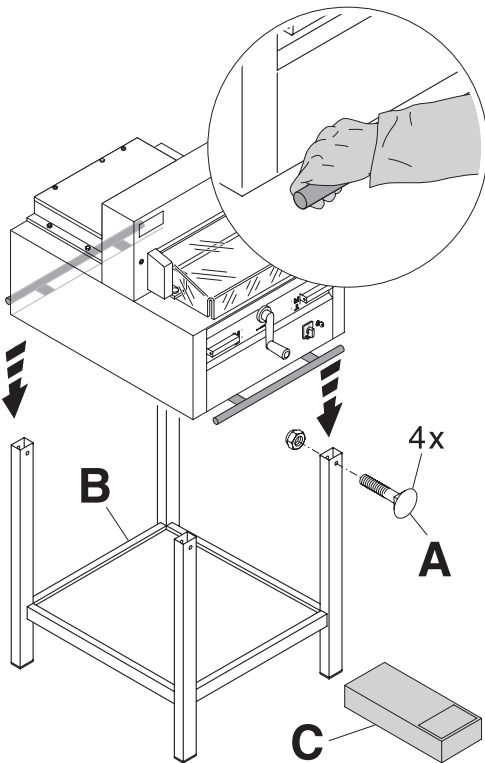

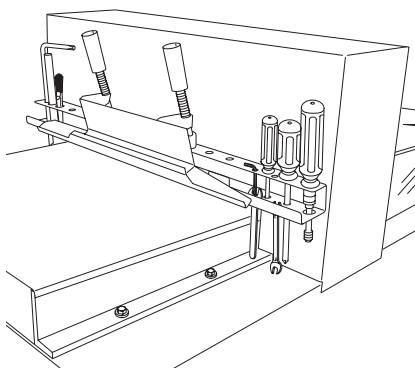

Tools can be kept in the holder provided .

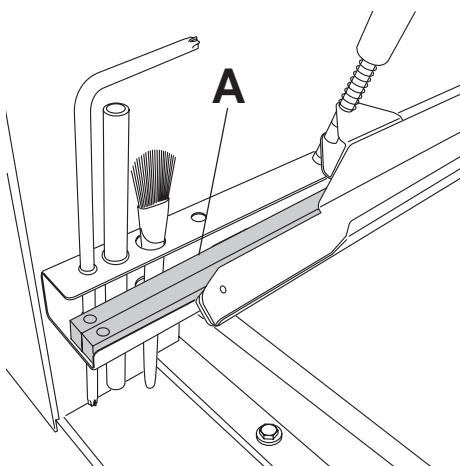

Cutting sticks (A) can be put in the tool holder

IDEAL 4815 • IDEAL 4850

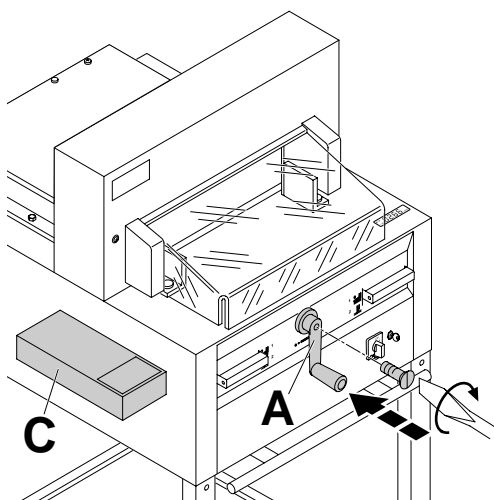

Tighten the backgauge crank (A). Parts and tools are in the tool set (C).

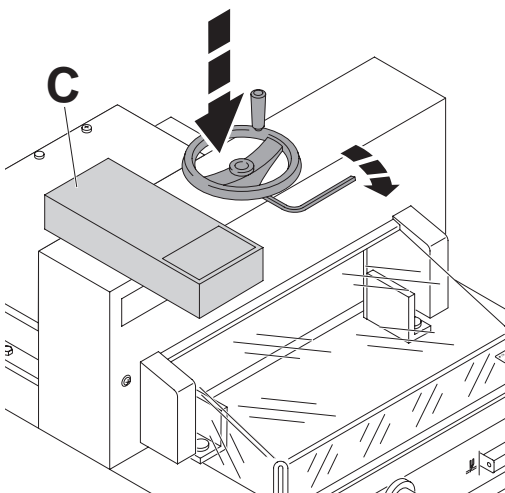

Only IDEAL 4815

Attach the enclosed hand-wheel for clamping. Parts and tools are in the tool set (C).

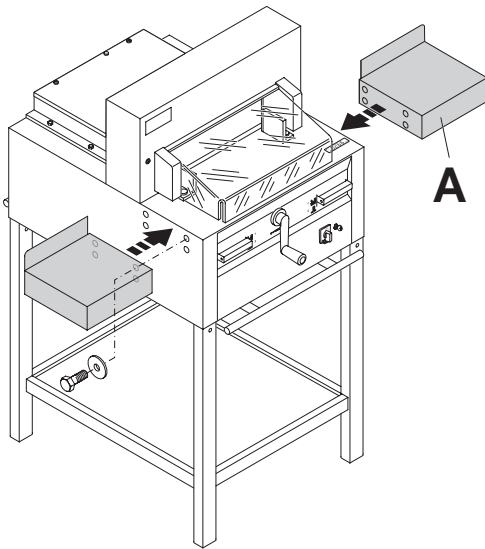

Side tables (A), left and right are available as an option (Nr. 9000 528).

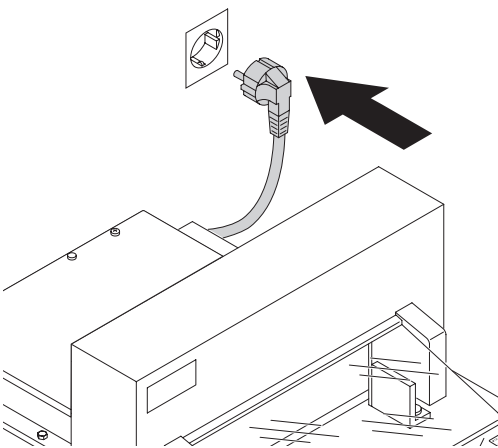

Plug into socket.

The machine must be connected directly to the socket.

IDEAL 4815 • IDEAL 4850

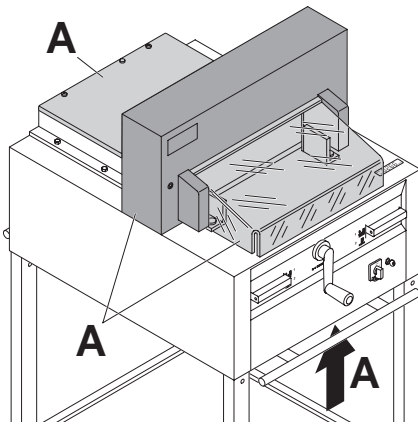

It is forbidden to operate the machine if the operating and safety instructions have not been understood. Please check the safety devices are functioning and complete before use.

- All covers have to be mounted (A).
- The release for cutting is allowed only if the cover is closed and the two-hand safety device is operated at the same time (B)
- If the front cover closes by itself the gas spring (X) needs replacing.

We recommend you keep a record of your test results.

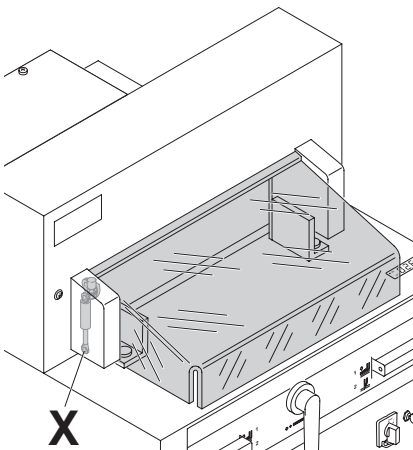
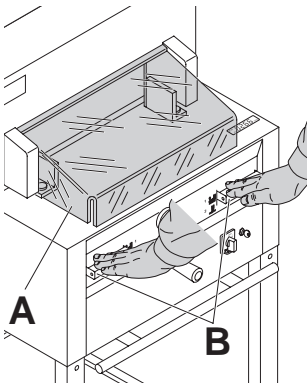

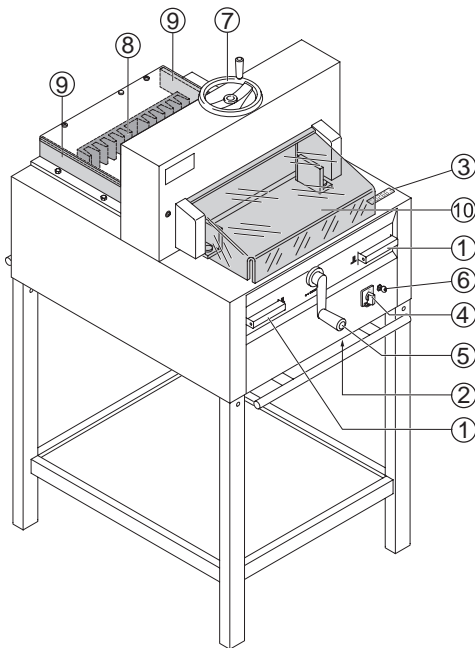

Operating elements

- ① - Safety two-handed control system
Pre-clamping (only IDEAL 4850)
and cutting
- ② - Overload switch
Blade drive IDEAL 4815
Blade drive, clamp drive,
IDEAL 4850
- ③ - Display cutting size (cm or inch)
- ④ - Main switch
- ⑤ - Crank handle for backgauge
setting
- ⑥ - Key switch
- ⑦ - Paper clamp (only IDEAL 4815)
- ⑧ - Backgauge
- ⑨ - Side lay left and right
- ⑩ - Front safety guard
- ⑪ - Measuring unit (cm or inch)
- ⑫ - Display cutting size (cm or inch)
- ⑬ - Changeover (cm/inch)

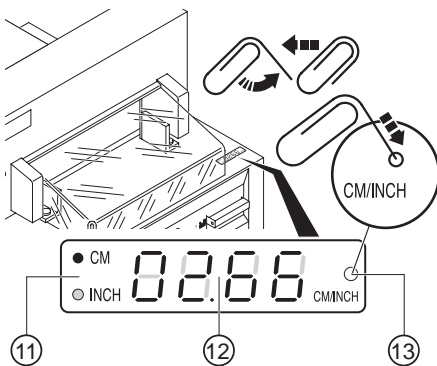

⚠ Warning!

Before cutting a measurement please check that the measurement scale (cm or inch) is adjusted correctly. See left picture.

Cutting activation

⚠ Warning!

- Run backgauge to the front for turning the paper stack.
- Do not interrupt the upward movement of the blade by performing switching procedures.
- Close the front safety guard ⑩.
- Blade must always be at the top and be covered by the clamp. Do not touch the blade.

(see safety information on page 32).

⚠ Risk of injury!

IDEAL 4815 • IDEAL 4850

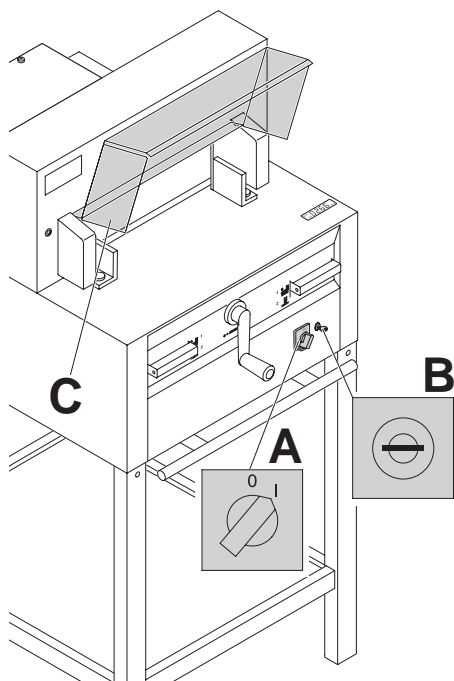

Position the main switch ④ to "I" (A). Insert the key ⑥ for the control system and move it to the right (B). Open the safety guard ⑩ (C). The machine is now ready for use.

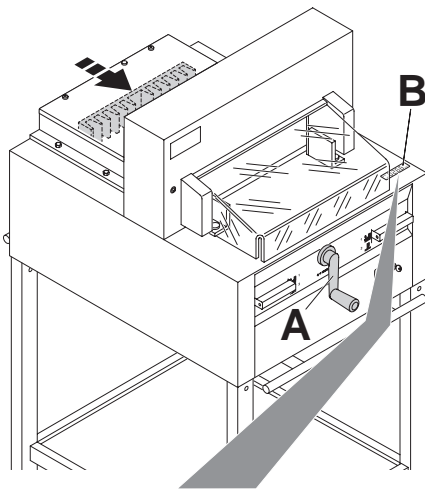

The measurement is set with the backgauge crank. (A) The symbol – rotary direction – \rightarrow moves to the right on the display (B) (see picture C). The rotary direction of the backgauge crank (A) is indicated on the right. Keep turning the backgauge crank to the right until a measurement appears (see picture E). The reference position is reached. The cutting size can now be set with the handle (A).

If the backgauge is right at the front the symbol – rotary direction – will move to the left (see picture D). Turn the backgauge crank to the left until the rotary direction appears on the right \rightarrow in the display (see picture C). Afterwards turn the backgauge crank to the right until a measurement appears (see picture E). The reference position is reached. The cutting size can now be set with the handle (A). Proceed to position \rightarrow from the rear.

Measurement is shown on the display in inches or cm (B).

Information:

When the machine is only switched off by the Key switch ⑥ (main switch ④ is still ON) it is not necessary to advance to the reference point.



IDEAL 4815 • IDEAL 4850

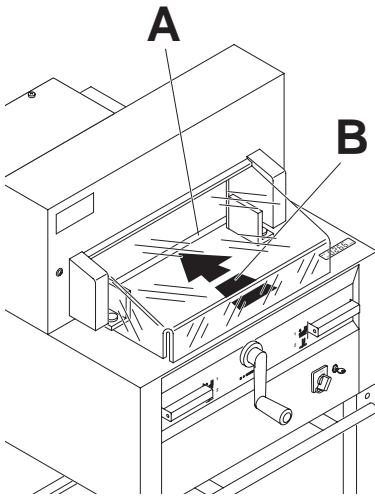

Cut according to markings

Optical cutting line (A) that indicates the exact position of the cut. Blade cuts on the front edge (B) of the light beam. (Only use when no exact cut is required).

- Adjust the backgauge with the crank handle ⑤ to the back.
- Insert paper and move by means of the stacking angle to the backgauge ⑧ and side lay on the left ⑨.
- Turn the crank handle ⑤ to the right until the marking on the paper to be cut is below the cutting line indicator.

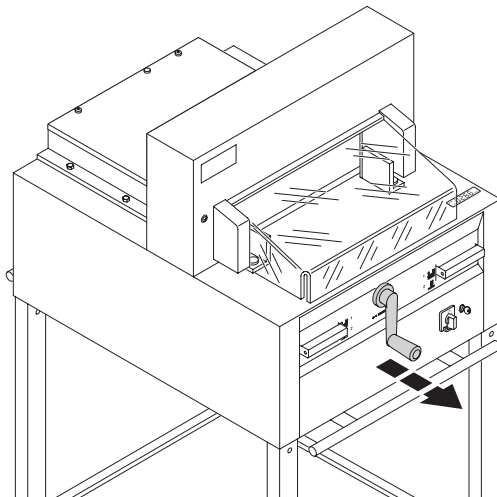

Pull out the handle to avoid the measurement being wrongly adjusted.

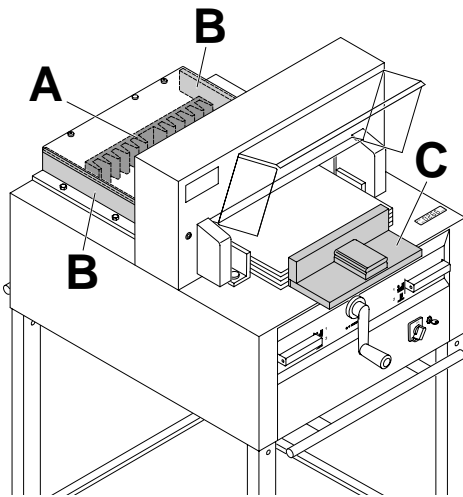

Position the paper on the backgauge (A) and side lays left or right (B).
To move paper stacks, please use the paper knock-up block (C) provided.
(Run backgauge to the front for turning the paper stack).

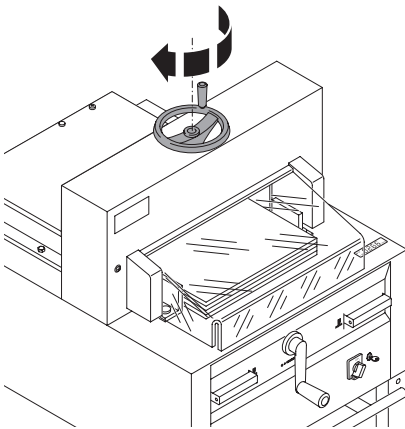

Only 4815

Clamping is released by the hand-wheel.
Before every cut lower the clamp by turning the hand-wheel to the right and tighten with a light twist.

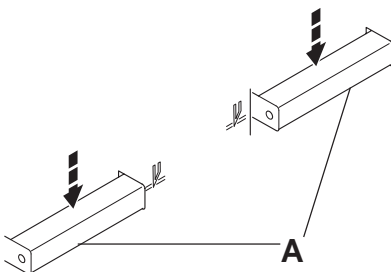

IDEAL 4815

Press both actuators of the two-handed control system activation (A) simultaneously and them pressed until the paper is completely cut.

IDEAL 4815 • IDEAL 4850

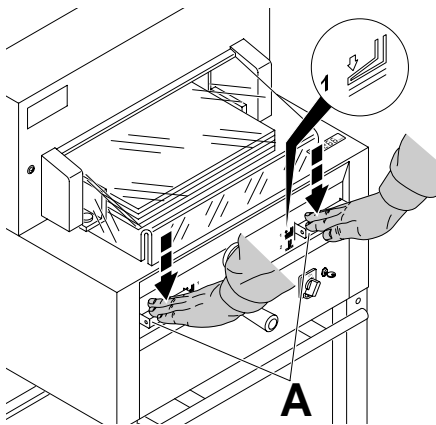

IDEAL 4850

The clamp moves automatically when cutting is activated.

The paper can also be pressed in advance. Clamping and cutting is activated by pressing actuators (A) on the front table.

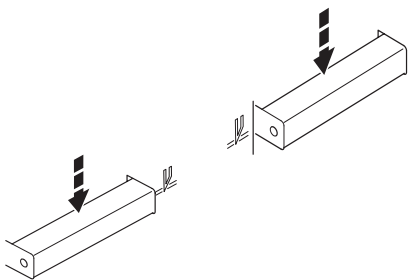

IDEAL 4850

The actuator has 2 switching steps:

1. pre-clamping
2. automatic clamping and cutting

IDEAL 4850

Switch position 1



Pre-clamping

Press down both actuators to step 1



Clamp returns

Press down completely one of the actuators

Switch position 2



Cutting sequence with automatic clamping

Press down both actuators to step 2

Close the safety guard.

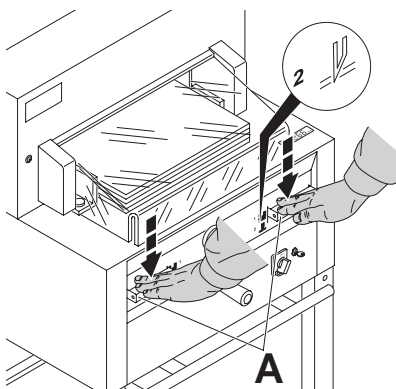
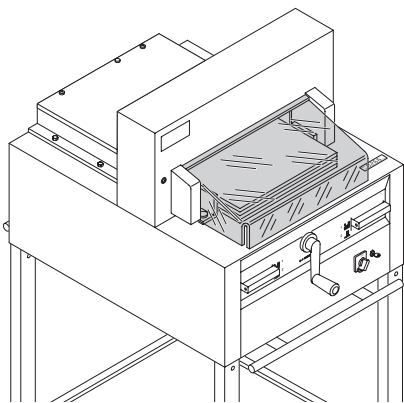

Cutting activation:

Press both buttons of the two-handed control system activation (A) simultaneously and then pressed until the paper is completely cut.

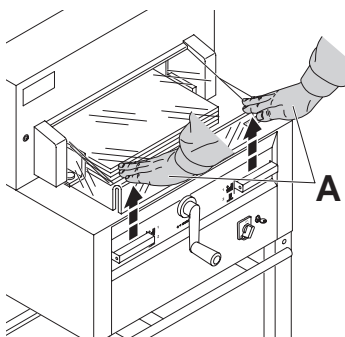

To interrupt or stop cutting:

To interrupt or stop cutting, release both buttons (A) of the two-hand control.

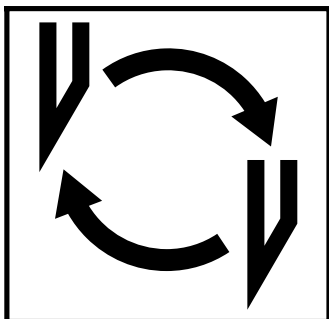

If the cutting quality decreases:

- Check the cutting depth (see page 32).
- Check the cutting stick (see page 28).
- Replace or grind the blade (see page 24 - 32).

The blade cannot be ground if the blade height is less than 83 mm/3,29 inches.

A new blade must be used.

The blade may only be ground by a qualified supplier or from the manufacturer Krug & Priester, D-72336 Balingen.

⚠ Danger! Risk of injury!

The blade is extremely sharp. Do not extract or transport the blade without protection. Changing the blade may only be performed by trained staff.

• Blade and cutting stick replacement •

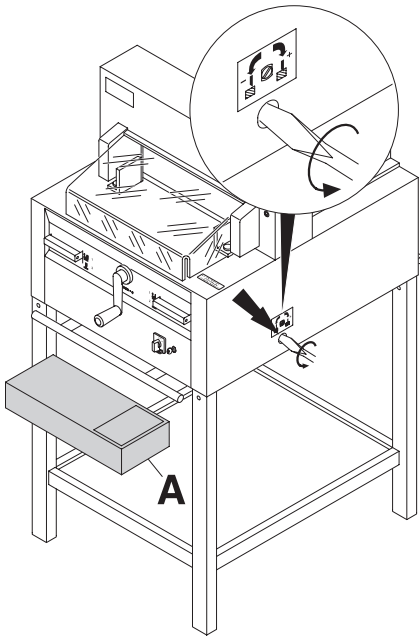

Turn the blade depth adjustment screw to the left until it stops. (Screwdriver found in tool set (A)).

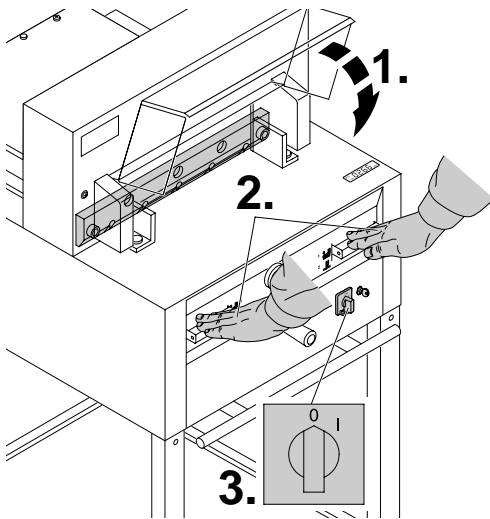

Close the safety guard (1.). Lower the blade by pressing both cutting actuators (2.). Keep one actuator pressed and turn off the main switch (3.).

IDEAL 4815 • IDEAL 4850

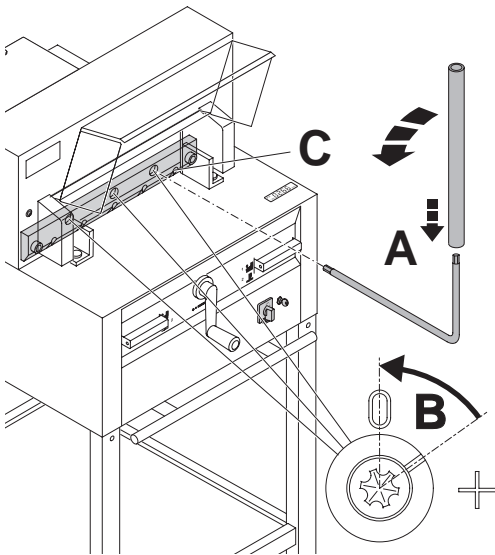

The 3 eccentrics are now exposed and should be turned counter clockwise to position "0" with the special wrench and attachable extension pipe (A) (in the tool set). The slot must correspond to position "0" (B). Unscrew the blade screws (C) on the right hand side.

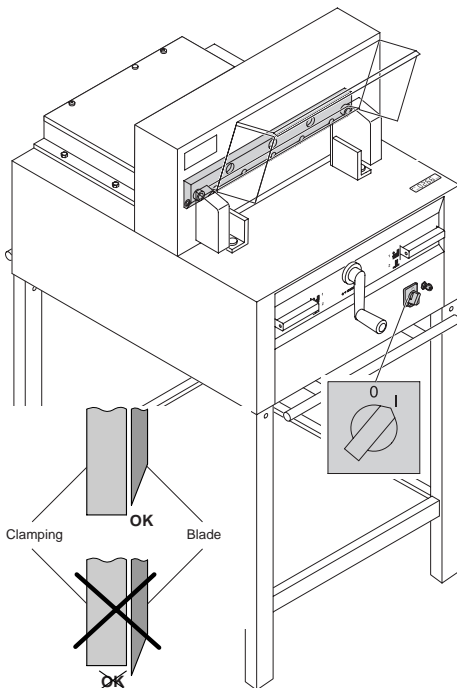

Remove the special wrench and turn on the main switch until the blade returns to the home position.

Warning by IDEAL 4815

Do not turn main switch to position "0" whilst blade is moving upwards!
The clamp must always overlap the blade!
 ⚠ **Danger! Risk of injury!**

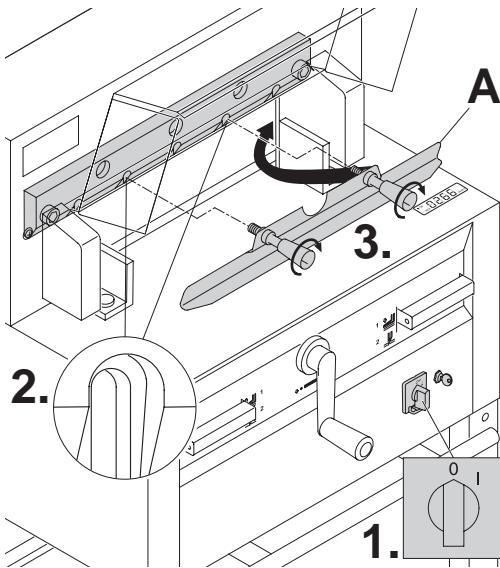

Position the main switch to "0" (1.)
Remove the 2 blade screws on the elongated holes (2.). Then put the blade changing tool (A) into place and fasten it to the blade (3.).

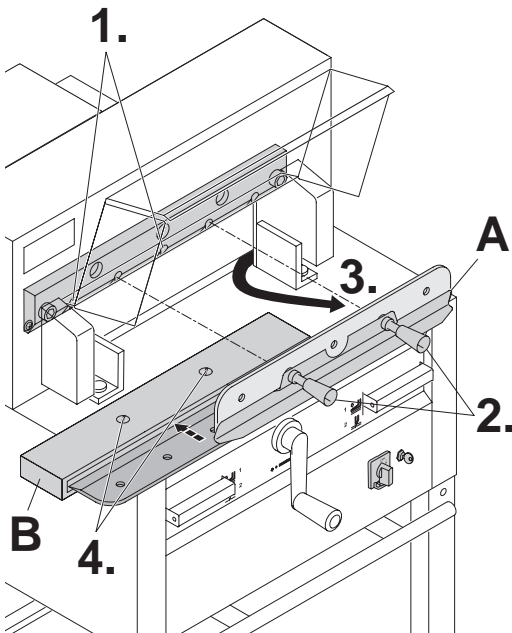

Remove 2 blade screws (1.).
Loosen the grips (2.) of the blade changing tool (A) lightly and allow the blade to be taken downwards out of the machine (3.). Place the blade into the blade carrier (B) and screw it into place (4.).

IDEAL 4815 • IDEAL 4850

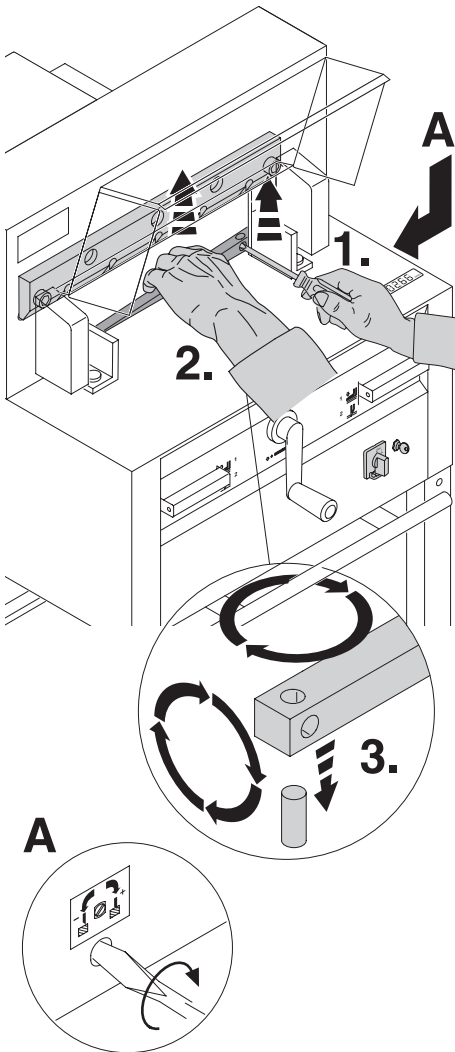

Take out the cutting stick with a small screw-driver. If needed the cutting stick can be turned or exchanged. (The cutting stick can be used eight times).

Replacing the cutting stick (not the blade).

- Turn the blade adjusting screw (A) to the left until it stops. (Otherwise the first cut will be too deep).
- Remove the cutting stick according to top picture.
- Turn the cutting stick (the non-used side must be near to the blade) and plug it into the holding bolt.

⚠ Danger! Risk of injury!

Cutting test after replacing the cutting stick (not the blade)

- Insert the paper and release the cut.
- If the last sheet of paper is not cut along the entire length turn the blade adjusting screw (A) ¼ turn to the right.
- If the last sheet is still not completely cut repeat this process until the last sheet is cut along the entire length.

• Blade and cutting stick replacement •

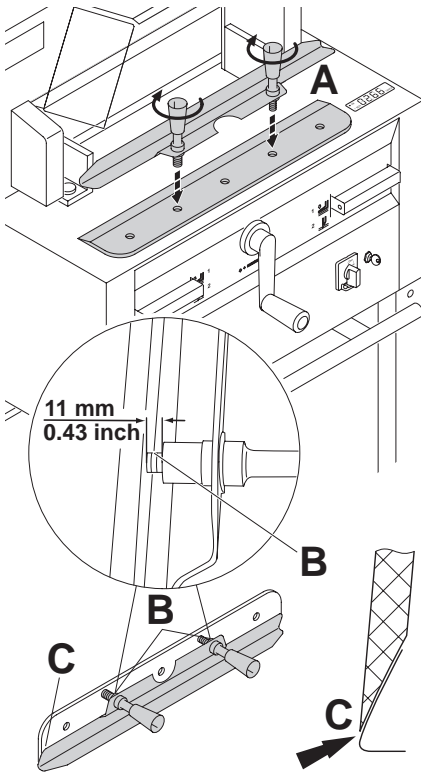

Take the exchange blade carefully out of the blade box and screw it to the blade changing tool (A).

- Make sure there is a space of 11 mm or 0.43 inches! (B).
- Blade must be covered! (C).

⚠ **Danger! Risk of injury!**

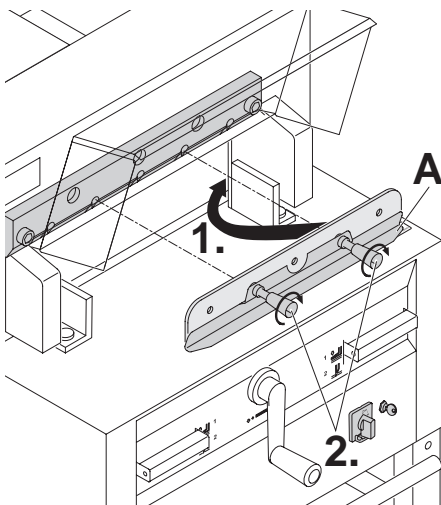

Place the blade to be exchanged with the blade changing tool (A) mounted (1.), into the blade carrier and push it up to the top and screw it into place with the grips (2.).

IDEAL 4815 • IDEAL 4850

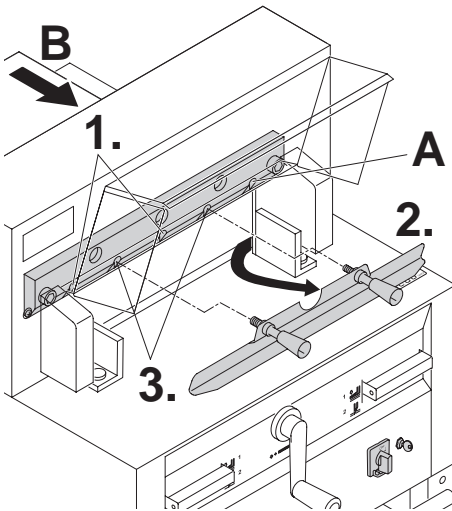

Lightly tighten 2 of the 5 blade screws with washers (1.). Remove the blade changing tool (2.). Lightly tighten the remaining blade screws with washers (3.). Lightly screw in the right blade screw with the washer (A) when the blade is lowered.

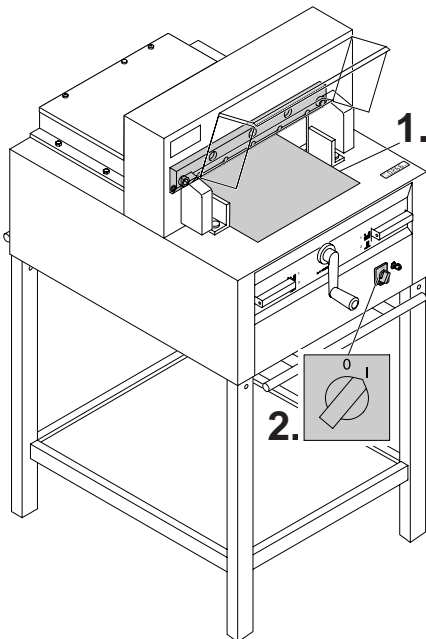

Remove all tools and distribute paper along the entire cutting length (1.). Turn main switch to position "I" (2.).

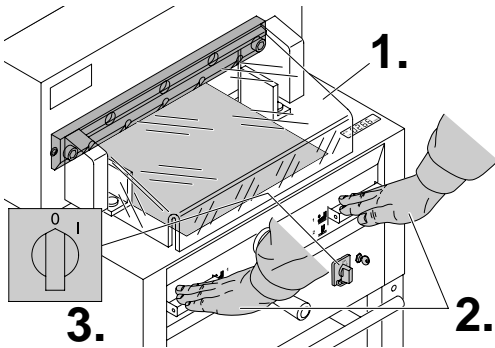

Close the safety guard (1.) Lower the blade by pressing both cutting buttons (2.). Keep one button pressed and turn off the main switch (3.).

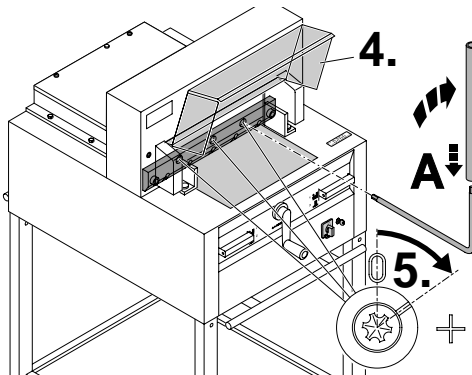

Open the safety guard (4.). With the special wrench (B) the 3 eccentrics should be screwed down (5.) until the paper is cut along the entire length of the blade (The blade must remain parallel, not too deep into cutting stick).

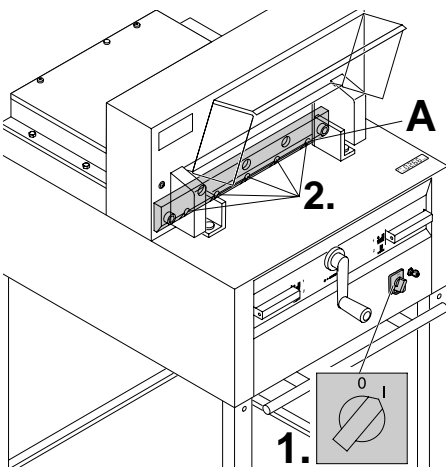

Tighten the blade screws (A) on the right hand side.

Turn main switch to position "I" (1.). Blade will return to upper position. Tighten the blade screws (2.) firmly.

Warning by IDEAL 4815

Do not turn main switch to position "0" whilst blade is moving upwards! The clamp must always overlap the blade! (see page 32).

⚠ Danger! Risk of injury!

IDEAL 4815 • IDEAL 4850

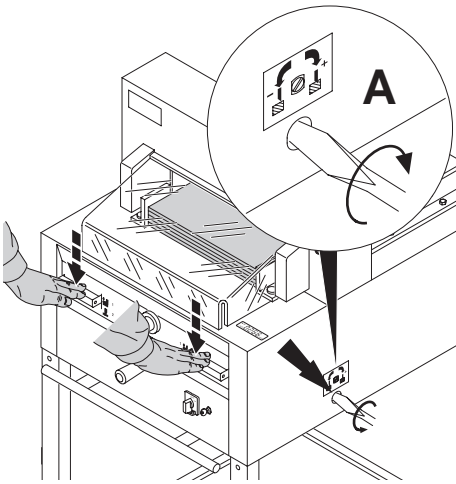

Paper cutting test. If the last sheet or several sheets are not completely cut, gradually turn the knob for blade depth adjustment (A) $\frac{1}{4}$ turn to the right until the paper is cut along the entire length. Do not set too low as blade will become blunt sooner.

Warning by IDEAL 4815

⚠ Danger!

Blade must always be covered by the pressing bar (see picture below at the left).

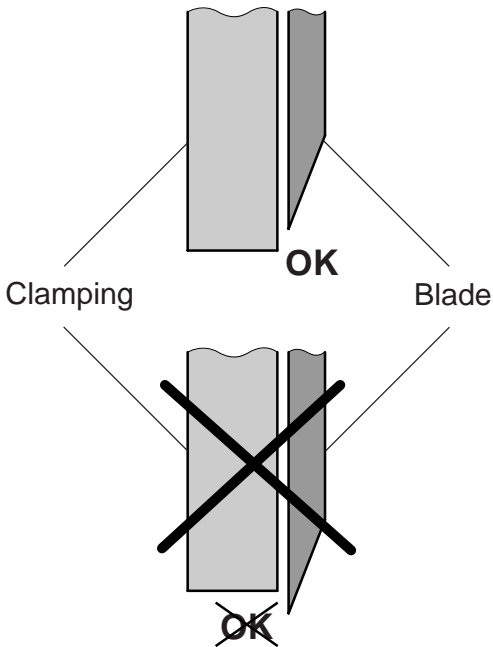

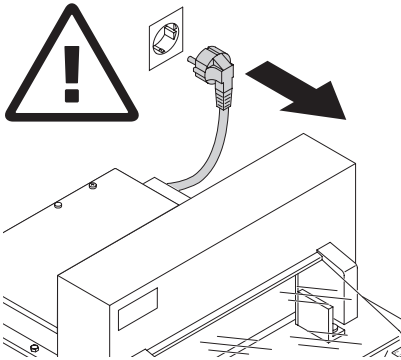

Maintenance work may only be performed by trained staff.

⚠ Danger! Disconnect the mains before starting any service work or before removing the cover.

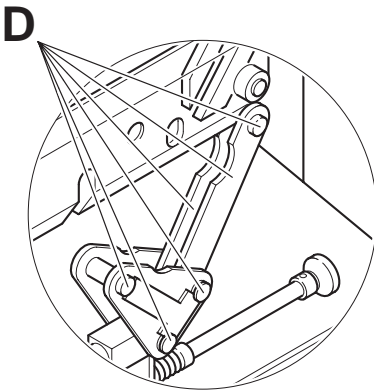

Grease the backgauge (A) control weekly with a grease gun. Advance the backgauge as far as possible to the front. (Use non-resinous oil or grease).

Grease the remaining parts twice a year (see picture).

The main switch must be on "0" (B). Remove panel (C). Tools in tool set.

- Remove any paper.
- Grease the machine.
- Check the 4 joining bolts and 2 pushing bars for wear (D). If necessary inform your service personnel.
- Mount the machine.

 = Greasing points on the machine.

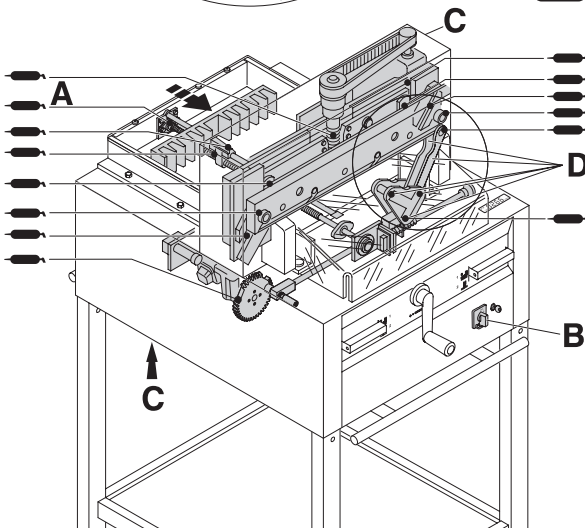



Safety test

The safety regulations are according to the regulations of the country where the cutting machine is operated. The manufacturer recommends a safety check is made every 5 years by an authorised service team.



Machine does not function!

Is the machine plugged in?

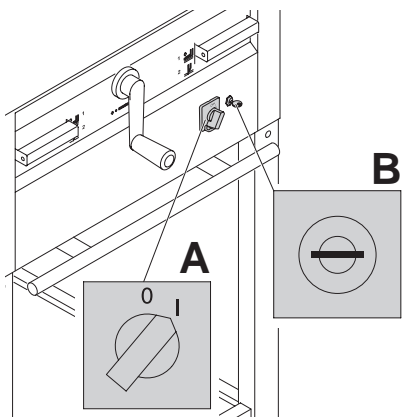
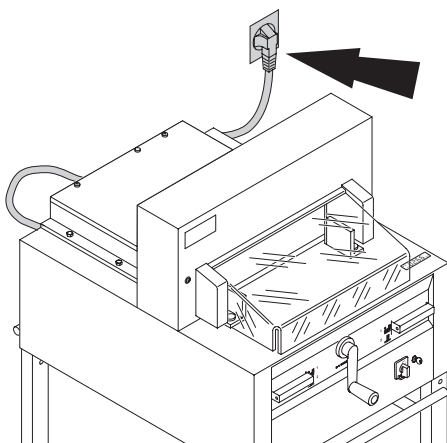

Main switch to position "I"? **(A)**
Control system activated? **(B)**
(Turn key to the right)
Check the units fuse and the on-site circuit breaker!
Release a cut see page 21 and 22.

IDEAL 4815 • IDEAL 4850

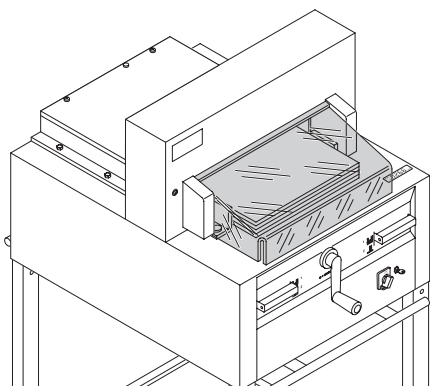

Cut cannot be made.

- If cover is open:
close it.
- If cover is closed:
open and re-close it. (Security check).

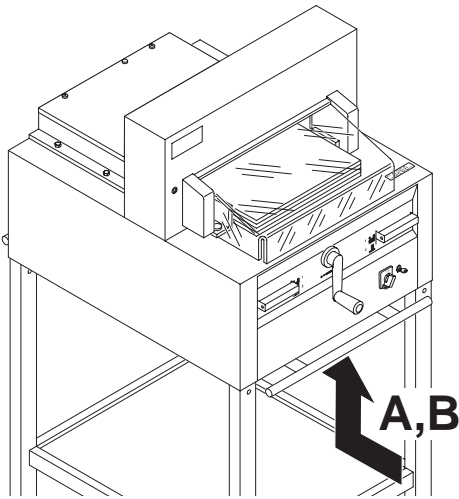

Machine turns off:

- Machine overloaded.
Safety button (A) ejects.
(Allow 1 minute cooling time and reset the safety button (A).
- Machine blocked.
- Blade is blunt.
Eliminate the cause, and push the safety button (A).

Only IDEAL 4850

- Clamping drive blocked
Safety button (B) ejects.
Eliminate the cause, and push the safety button (B).

Safety button for:



A = Blade drive

B = Clamping drive

IDEAL 4815 • IDEAL 4850

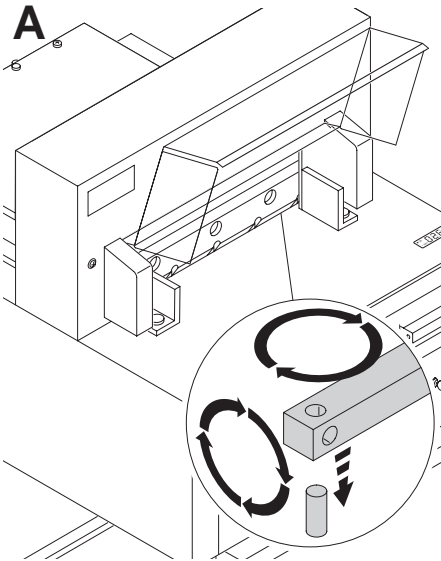

Does not cut through the last sheet:

- Turn or turn around the cutting stick (A), readjust the blade by means of the blade adjusting knob (B) (see page 32).

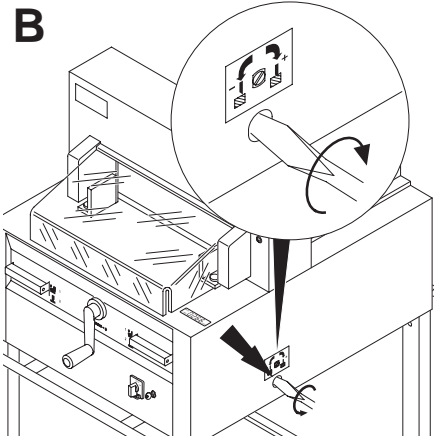

Poor cutting quality or blade stays in the paper stack.

- Change the blade (C) (see pages 24 - 32).

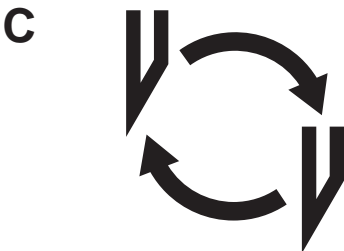

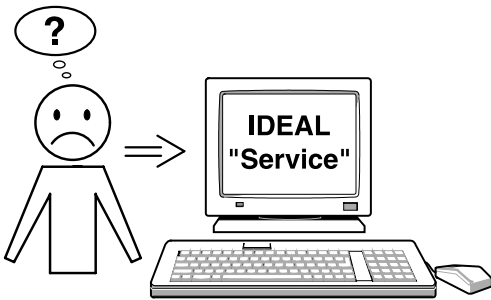

Motor runs but blade does not move downwards.

- Security brake has been activated!
Inform the Service Team!
- www.ideal.de → "Service"
service@krug-priester.com

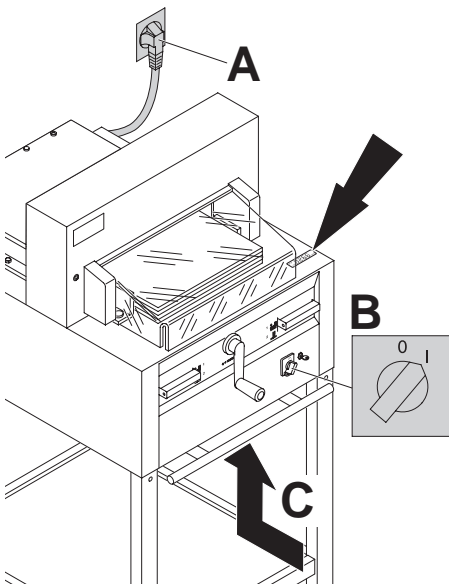

Display illumination off

- Machine is plugged in? (A)
- Main switch on position "I"? (B)
- Push in the safety button! (C)
- Check the units fuse and the on-site circuit breaker!

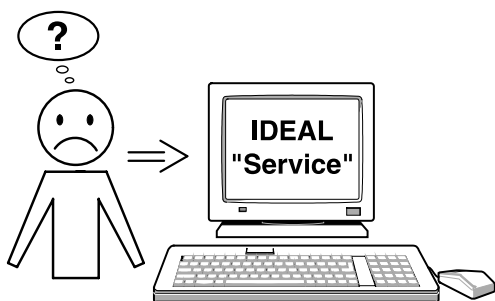

None of the above mentioned methods helped to solve the problem:

Contact Service Team under

- www.ideal.de → "Service"
- service@krug-priester.com

Recommended accessories:

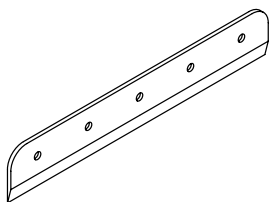

Blade

- Nr. 9000 021

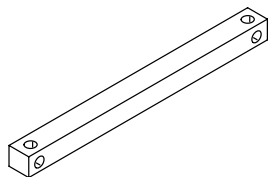

Cutting stick (6 pieces)

- Nr. 9000 022

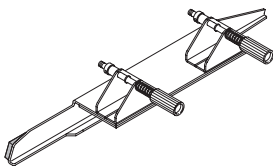

Blade changing tool ¹

- Nr. 9000 518

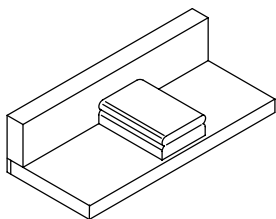

Paper knock-up block ¹

- Nr. 9000 521

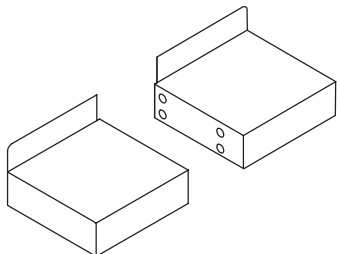

Side tables left and right ¹

- Nr. 9000 528

¹ Included in delivery

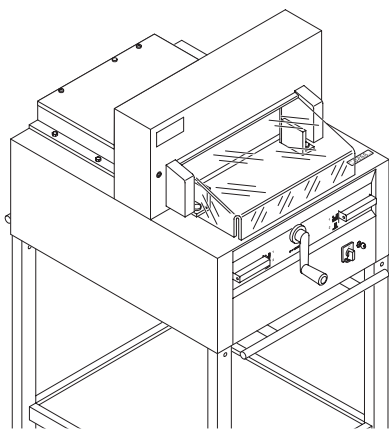
IDEAL 4815 • IDEAL 4850**Technical data:**

- Power supply: 230V/50Hz/1~, 120V/60Hz/1~
- Cutting height: 80 mm
- Sound level EN 13023: < 70 dB (A)
- Leakage current < 3,5mA
- Power cord gauge min. 1,5mm² (230V).
- Power cord gauge AWG 14 (15A) (120V) (IDEAL 4815)
- Power cord gauge AWG 12 (20A) (120V) (IDEAL 4850)

The exact technical specifications can be found on the technical specifications sticker (A) on the machine. A wiring diagram is found in the electrical switch box.

To claim under guarantee, the machine must still carry its original identification label.

	Cutting-length mm	Table- depth mm	Minimum space requirement (B X T X H) mm	Weight kg
IDEAL 4815	475	458	765* x 1080 x 1435	212**
IDEAL 4850	475	458	765* x 1080 x 1300	225***

* with side tables: 1365 mm

** with side tables: IDEAL 4815 / 221 kg

*** with side tables: IDEAL 4850 / 234 kg



This machine is approved by independent safety laboratories and is in compliance with the EC-regulations 2006/42/EG and 2004/108/EG.

Sound level information:

The sound level is < 70 db (A) as defined by EN 13023.

Subject to alteration without notice.



I.T.E. Listed 802 D

IDEAL 4815 • IDEAL 4850



Krug + Priester has a certified quality management system according to DIN EN ISO 9001:2008 and a certified environmental management system according to DIN ISO 14001:2009.



D EG-KONFORMITÄTSERKLÄRUNG
GB EC-declaration of conformity
F Déclaration de conformité CE

- Hiermit erklären wir, daß die Bauart von
- Herewith we declare that
- Par la présente, nous déclarons que

	GS- IDENT. Nr.	UL- IDENT. Nr.
4815	11481001	10481001
4850	11485001	10485001

- folgenden einschlägigen Bestimmungen entspricht
- complies with the following provisions applying to it
- sont conformes aux dispositions pertinentes suivantes

2006/42/EG:

Maschinenrichtlinie, EC Machinery directive, EC Directives machines.

2004/108/EG:

EMV Richtlinie, EMV Electromagnetic compatibility directive,
EMV directives compatibilité électromagnétique

2011/65/EU

RoHS Richtlinie, RoHS directive, RoHS directives.

- Angewendete harmonisierte Normen insbesondere
- Applied harmonised standards in particular
- Normes harmonisées utilisées, notamment

EN 60204-1; EN 1010-1; EN 1010-3; EN 55014-1; EN 55014-2;
EN 61000-3-2; EN 61000-3-3; EN ISO 12100;
EN ISO 13857; EN ISO 11204; EN 13023; EN ISO 13849-1

29.12.2009
Datum

Bevollmächtigter für technische Dokumentation
Authorized representative for technical documentation
Représentant autorisé pour la documentation technique

M. Priester

- Geschäftsführer-

Krug & Priester GmbH u. Co KG
Simon-Schweitzer-Str. 34
D-72336 Balingen (Germany)

IDEAL 4815 • IDEAL 4850

Remarks:

Remarks:

• Document Shredders •



• Trimmers and Guillotines •

