

Spinnit<sup>®</sup> FMM-3 Three Spindle Paper Drill

**USER'S MANUAL**



*Before operating this equipment, please read these instructions completely and keep these operating instructions for future reference.*

Serial Number: \_\_\_\_\_  
Date of Purchase: \_\_\_\_\_  
Dealer: \_\_\_\_\_  
Address: \_\_\_\_\_  
\_\_\_\_\_  
\_\_\_\_\_  
Telephone Number: \_\_\_\_\_

# Table Of Contents

## Introduction

- Introduction..... Page 02
- Shipping Damage Inspection..... Page 02

## Safety Information

- Safety Instructions..... Page 03
- Warning Labels..... Page 03

## Setting Up Your Machine

- Loose Item Inventory..... Page 04
- Leveling Feet..... Page 05
- Paper Side Stops..... Page 05
- Master Chip Chute..... Page 05
- Chip Bag..... Page 06
- Electrical Start Up..... Page 06

## Operating Instructions

- Drill Bit Removal and Installation..... Page 07
- Leveling the Drill Bits..... Page 08
- Adjusting the Table Height..... Page 09
- Back Gauge Adjustment..... Page 09
- Adjusting the Distance Between the Heads..... Page 10
- Adjusting the Stop Collars..... Page 10
- Multi-hole Set Up..... Page 11
- Traversing the Table..... Page 11
- Drilling Procedures..... Page 12
- Tips On Drilling..... Page 12

## Maintenance

- Every 12 Months..... Page 13 - 15

## Trouble Shooting Guide

- Problem,Cause, and Correction.....Page 16 - 18

## Parts Diagrams

- Side View..... Page 19
- Head Assembly..... Page 20
- Spindle and Chuck Assembly..... Page 21
- Rear View..... Page 22
- Parts List..... Page 23

# Introduction

## Introduction

- Thank you for your purchase of the Spinnit® FMM-3 Paper Drill.
- We ask that you take a moment to fill in the serial number and other information on the front cover of this manual. Please keep this manual as a reference for future use.
- For parts and service please contact the Lassco-Wizer Dealer from whom you purchased the machine. If you require assistance in locating a Lassco-Wizer Dealer, please contact our customer service department at 585-436-1934. Please have the model of your machine and the serial number when you call.
- If you wish to write to us please contact us at:

Lassco-Wizer  
485 Hague Street  
Rochester, NY 14606

## Shipping Damage Inspection

- Remove the machine from the carton and inspect for any shipping damage. If any damage is present, report the damage to the carrier immediately. Failure to do so may void any warranties.

# Safety Information

## Safety Instructions

- All operators must read and understand the Users Manual and all other safety instructions before using this equipment. Failure to fully understand the safety instructions may result in personal injury. If, after reading the manual, you are still uncertain about use, please contact the dealer from whom you purchased the machine for assistance. If you need contact information for a Service Technician nearest you please call 585-436-1934.
- Safe operation of this equipment is the responsibility of the users.
- This machine is designed for one person operation. Never operate the machine with more than one person.
- Keep hands, hair, and loose clothing away from the drills when operating.
- Please read and follow all warning labels on your machine. (See below for a list of all warning labels)
- Always turn the machine to off mode and unplug the machine before installing or removing drill bits and before servicing the machine. Keep hands away from drills when operating. **PLEASE NOTE THAT THE DRILL BITS MAY BE HOT AFTER USE. PROCEED WITH CAUTION WHEN CHANGING THE DRILL BITS.**
- **ONLY A SERVICING TECHNICIAN IS TO SERVICE THIS MACHINE.**

## Warning Labels

- The following labels appear on your FMM-3 paper drill. Make sure all operators understand and follow the safety instructions.



Please read and make sure that all operators understand the user's manual and all other safety instructions before using this equipment.



Keep hair, jewelry, loose clothing and any other items that could become entangled pulled back away from the machine when drilling.

# Setting Up Your Machine

## Loose Item Inventory

■ Remove and inspect the following items:

FMM6-651A: Master Chip Chute (1)

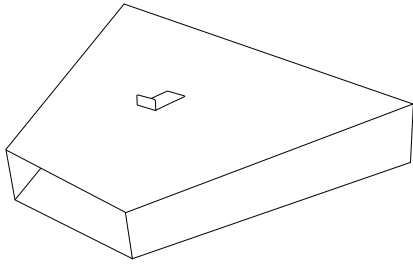

FM4-4001: 25" Drill Strip (1)

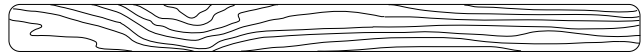

This item comes installed

FMM6-652A: Chip Bag Assembly (1)

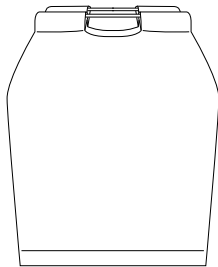

MS-1: Drill Sharpener (1)

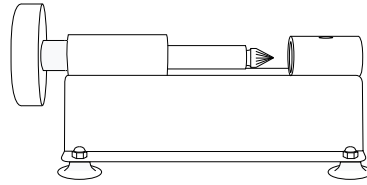

Hollow Drill Bit (3)

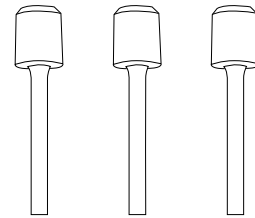

These items come installed

FM4-4006: Paper Side Stops (2)

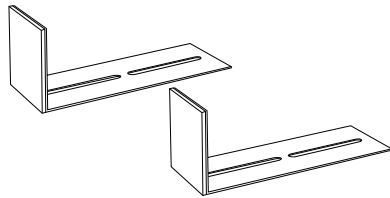

EBM-32: Chuck Release Key (1)

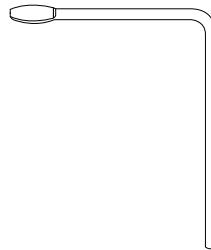

FMM9-956A: Spindle Rotation Tool (1)

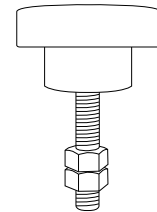

Spin-Eze™  
Drill Bit Lubricant (1)



EBM-41:  
Sharpending  
Stone (1)

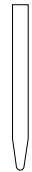

CC-2: Chip Clearer (1)

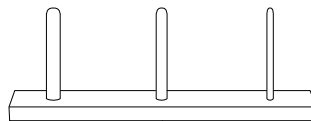

FM4-4007: Side Stop Screws (4)

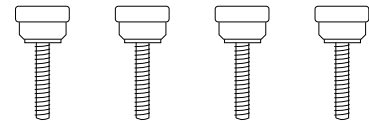

HEX-532-T: Hex Wrench 5/32" (1)



HEX-332:  
Hex Wrench 3/32" (1)



Short Set Screws (2)

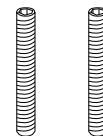

Items are not to scale

# Setting Up Your Machine

## Leveling Feet

- Step #1** ■ If needed, adjust the feet on the underside of the base to level the machine. Start by loosening the Lock Nuts from inside the stand. Level by rotating the feet up or down to the desired height as shown. When they are adjusted as desired, tighten down the Lock Nuts again.

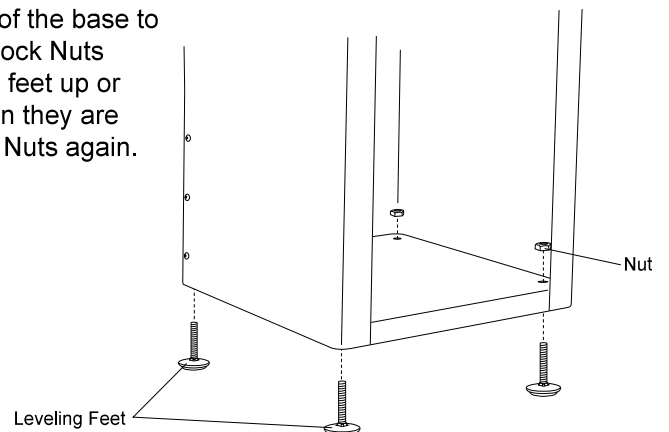

Base of the Machine

## Paper Side Stops

- Step #2** ■ Attach the Paper Side Stops (FM4-4006) using two Side Stop Screws (FM4-4007) each. Position the Paper Side Stop as desired and tighten down with light pressure.

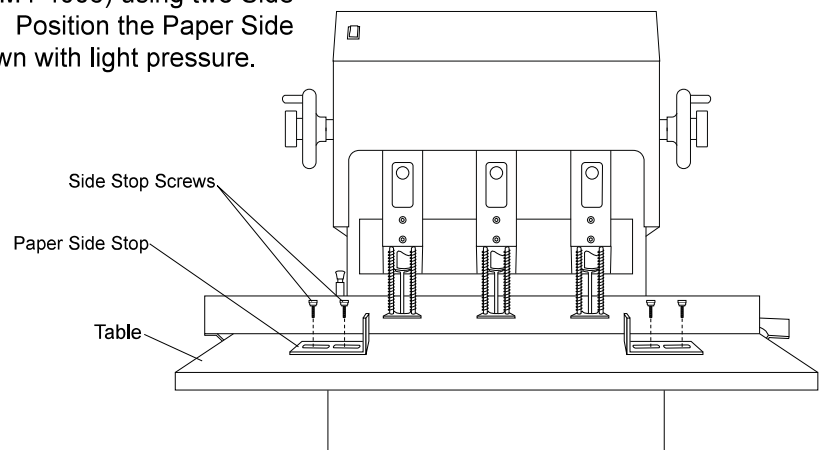

## Master Chip Chute

- Step #3** ■ Attach the Master Chip Chute (FMM6-651A) by inserting the two hooks located on the wide end of the Master Chip Chute into the rectangular opening in the upright as shown. The hooks are on the bottom of the Master Chip Chute and hook over the bottom of the opening.

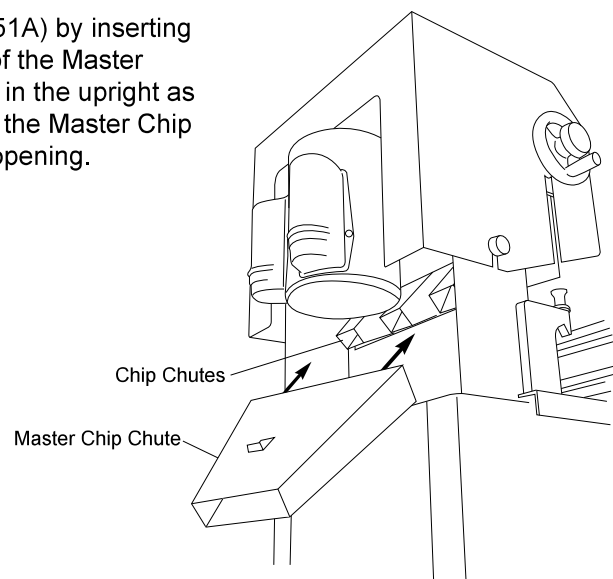

# Setting Up Your Machine

## Chip Bag

- Step #4** ■ Attach the Chip Bag (FMM6-650A) to the machine by stretching the mouth of the bag over the Master Chip Chute and hooking the aluminum bar onto the bracket located on the top flat portion of the master chip chute as shown. Please note that you must empty this bag as needed to avoid clogging.

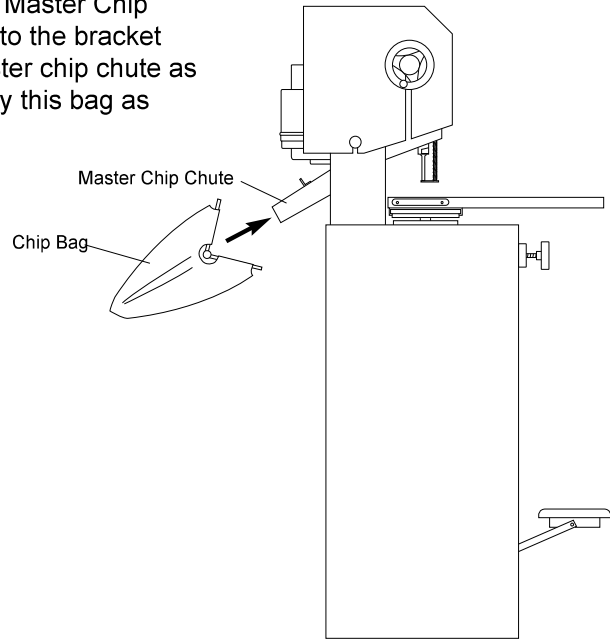

## Electrical Start Up

- Step #5** ■ Making sure that nothing is interfering with the drill bits, plug the cord set into a grounded 115V outlet. To turn the machine on, press the Rocker Switch on the front of the shroud.

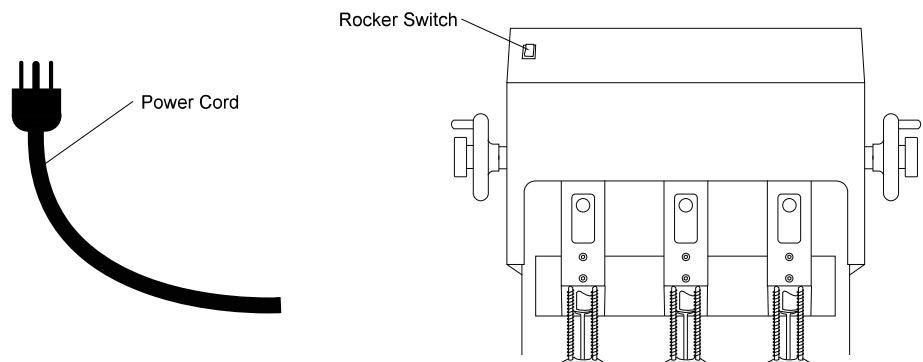

# Operating Instructions

## Drill Bit Removal And Installation

**Note:** Please note that drill bits may be hot after drilling. Please wait to change drill bits until they have cooled down.

**Step #1** ■ Remove the hole guard which is attached to the chuck. This is done by grasping the tab and sliding the guard off.

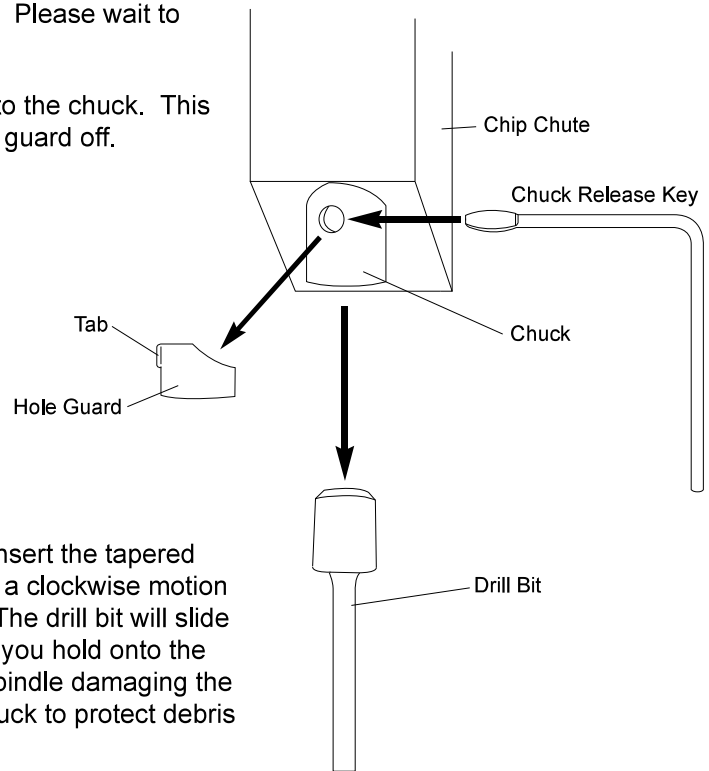

**Step #2** ■ Using the Chuck Release Key (EBM-32), insert the tapered end facing down into the chuck hole. With a clockwise motion turn the Chuck Release Key 45 degrees. The drill bit will slide out of the spindle. It is recommended that you hold onto the drill bit so that it does not drop out of the spindle damaging the tip. Place the hole guard back onto the chuck to protect debris from clogging the spindle.

**Step #3** ■ To install a drill bit, grasp the drill bit and being careful to keep it straight, press it up into the Chuck.

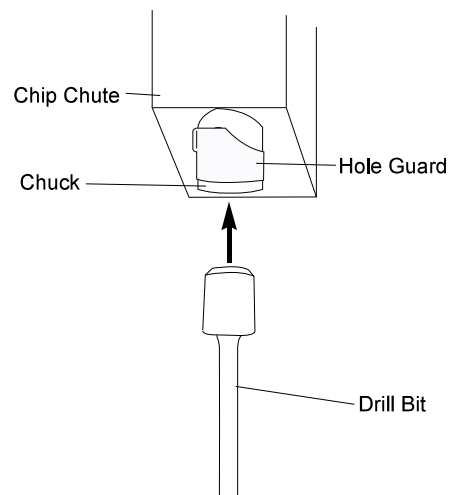

**Step #4** ■ Seat the drill bit by using a stack of scrap paper. Set the scrap on the table as shown. Step on the foot pedal slowly raising the table toward the drill bit. Put light pressure on the hollow drill bit seating it firmly in place. Remove the scrap paper and turn the machine on to check the concentricity of the bit. If the bit is not concentric, remove it and repeat steps 3 and 4 until it is concentric.

# Operating Instructions

## Leveling The Drill Bits

### Step #5 ■ To level the Drill Bits:

1. Insert the Spindle Rotation Tool (FMM9-956A) into the end of the motor shaft through the opening in the top of the machine shroud.
2. Swing the access cover located on the front of the heads to one side allowing access to the spindle and chuck.
3. Turn the Spindle Rotation Tool by hand until the insert retainer screw can be seen in the opening.
4. Stepping slowly on the foot pedal, raise the table so that it meets the bottom of the pressure foot assembly.
5. Using the 5/32" Hex Wrench (HEX-532-T), loosen the insert retainer screw and lower the chuck by pulling down on it until the drill bits meet the table surface.
6. When the drill bit is just touching the drill strip, re-tighten the insert retainer screw.
7. Repeat steps 1 - 6 on the remaining Drill Bits so that they are all level with each other.
8. Remove the Spindle Rotation Tool from the motor shaft.
9. Replace the access covers so that they cover the openings.

**Note:** We recommend using a piece of card stock on the Table when leveling the drill bits to avoid drilling into the drill strip. This will lengthen the life of your drill bits and keep them sharper.

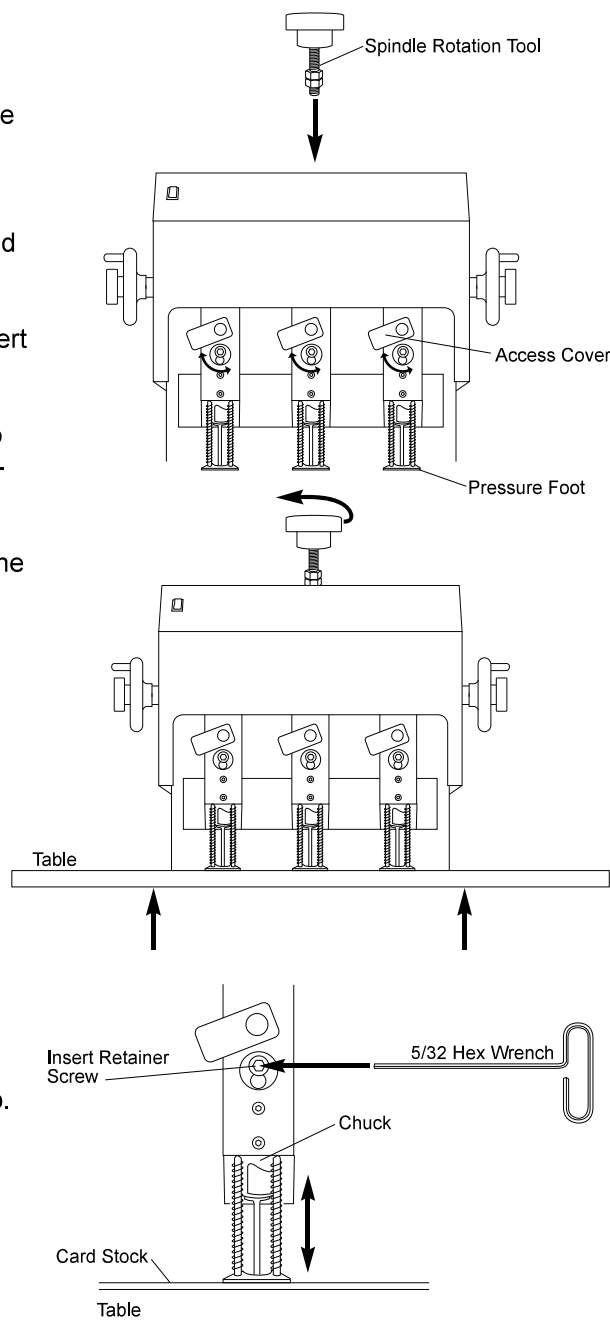

# Operating Instructions

## Adjusting the Table Height

**Step #6** ■ After you level the drill bits you may need to adjust your table height. Test drill through a stack of scrap approximately the same height as that you will be drilling. If the drill bits drill into the Drill Strip or if the drill bits fail to penetrate through the bottom sheet of scrap you will need to adjust the table height. If you are using the card stock under your scrap (recommended) then you should just be lightly scoring the card stock when the table is in its full upright position. If your bits are drilling correctly move onto Step #7.

■ **If your drill bits fail to penetrate through the scrap:**

Loosen the Lock Knob of the Vertical Stop Adjustment Assembly and rotate the large knob counterclockwise allowing the table to travel higher. Tighten down the Lock Knob when it is positioned correctly.

■ **If you are drilling into the Drill Strip:**

Loosen the Lock Knob of the Vertical Stop Adjustment Assembly and rotate the large knob clockwise allowing the table to travel lower. Tighten down the Lock Knob when it is positioned correctly.

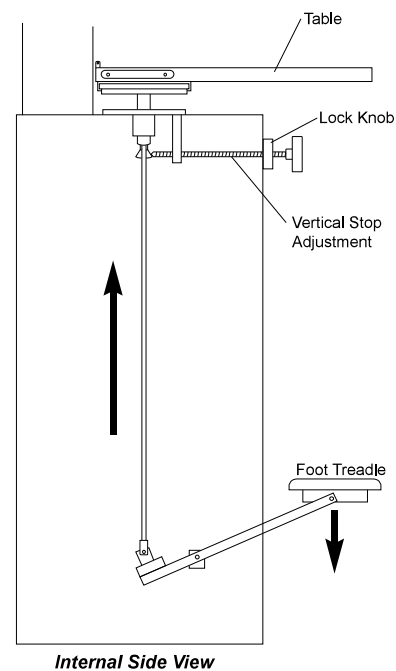

## Back Gauge Adjustment

**Step #7** ■ Adjust the Back Gauge so that it is the correct distance from the edge of the product to the center of the hole to be drilled by performing the following:

1. Loosen the Clamp Knob on the right side of the Back Gauge.
2. Using the two Scales embedded in the rear corners of the table, align the front edge of the Back Gauge with the desired distance.

**Note:** Zero (0) on these scales align with the center of the hollow drill bits.

3. Tighten down the Clamp Knob when the Back Gauge is positioned as desired.

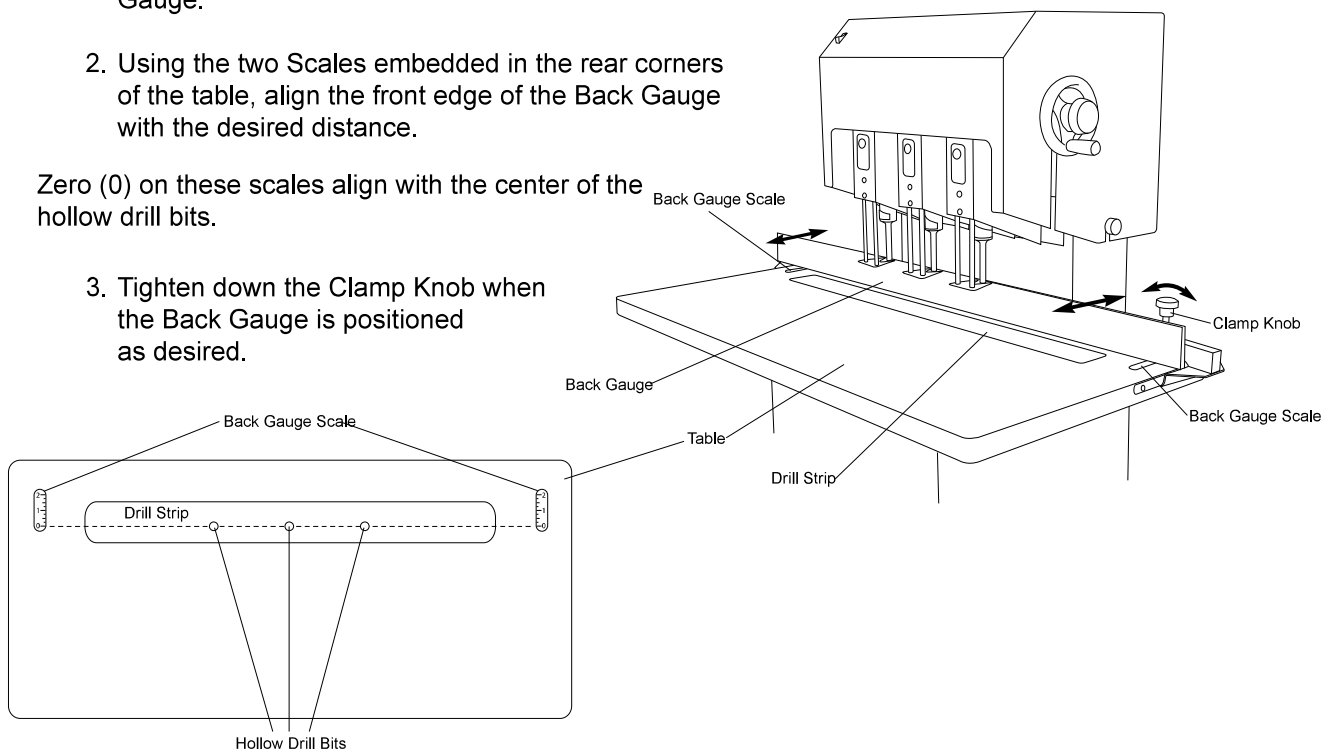

# Operating Instructions

## Adjusting The Distance Between The Heads

- Step #8** ■ To adjust the outside spindles to a desired spacing, loosen the Hand Wheel Lock Knob. Turn the Hand Wheel to move the spindle farther away from the center or to move the spindle closer to the center. Please note that the direction you turn the Hand Wheel depends on the side of the machine. Use the Back Gauge Scale as a guide. When the spindle is at its desired location tighten the Hand Wheel Lock Knob by turning clockwise. Repeat with the second outside spindle.

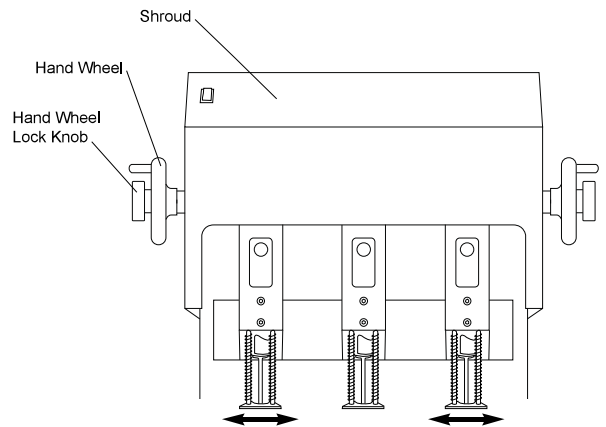

**Note:** The center spindle is stationary.

**Note:** When drilling fewer than three holes simply remove undesired drill bits.

## Adjusting The Stop Collars

- Step #9** ■ The stop collars, located on the Stop Rod at the left rear of the Table, are used to either create a stationary table mode of operation or a traversing mode.

**Note:** Your machine comes set up in stationary mode.

### For traversing table operations:

1. Install the shorter Set Screws included with the machine into the Stop Collars. Make sure all the Stop Collars are installed with the shorter Set Screws keeping them loose enough to allow the Stop Collars to slide into the desired positions.
2. Set the Stop Collars using the method explained on page 11.
3. When the Collars are positioned as desired, tighten down the short Set Screws locking them in place using the provided Hex Wrench (HEX-332).

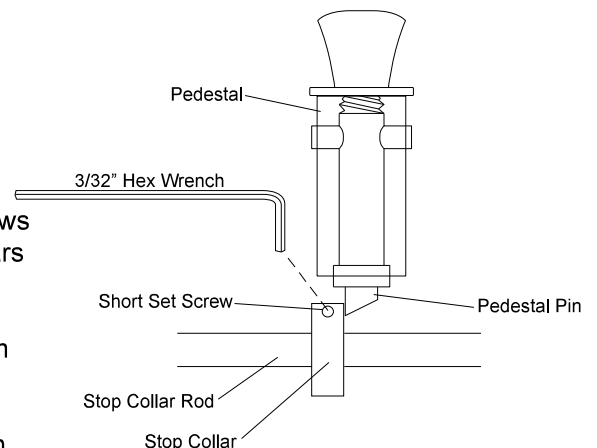

### For stationary table operations:

1. Align the table so that zero (0) on the Back Gauge is aligned with the center drill bit.
2. Install two longer Set Screws included with the machine into the adjacent Stop Collars.
3. Tighten, with the provided Hex Wrench (HEX-332), the longer Set Screws into the Stop Collars so that a Set Screw rests against each side of the Pedestal preventing movement of the Table.

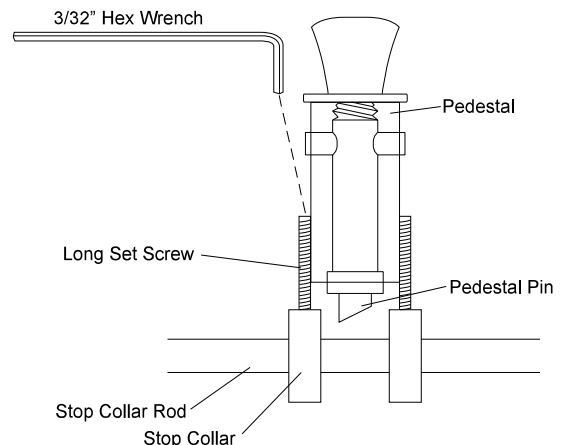

# Operating Instructions

## Multi-hole Set Up

**Step #10** ■ If a hole pattern includes more than three holes, you will need to adjust the Stop Collars to the desired spacing. The Stop Collars are adjusted as described in *Step #9* of the *Operating Instructions*. Measure the distance between the stop collars in the following manner:

1. Locate the product on the Table and adjust the Paper Side Stops to trap the material allowing no lateral movement.
2. Move the Table to align zero (0) on the Back Gauge Scale with the center drill bit.
3. Loosen the Stop Collars and position the first one against the Pedestal Pin marking the beginning position of the Table and tighten in place.
4. The right side of this Stop Collar now indicates the center of the product to be drilled. Place the remaining Stop Collars as desired by measuring with a Ruler (not provided) to the desired positions and tighten them down. Always measure from the right side of the Stop Collar to the right side of the next Stop Collar as shown.

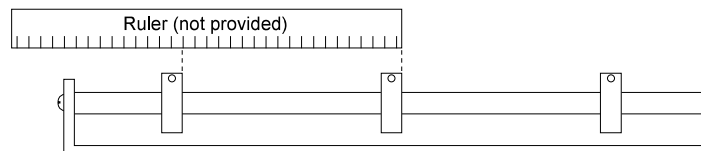

**Note:** Due to the width of the Stop Collars, the shortest travel between holes is  $3/8$ ". Almost any center-to-center distance can be drilled, but requires variations of table travel and lateral head adjustments.

## Traversing The Table

**Step #11** ■ When all the Stop Collars are positioned as desired return the Table to its original position. When traversing the Table during drilling (See Page #12 for *Drilling Procedures*), move the Table to the left until the Pedestal Pin "clicks" over the next Stop Collar. Pull the table back to the right and hold it there to assure contact between the Stop Collar and the Pedestal Pin. Continue drilling and repeat as needed.

- To reverse the direction of the Table traverse, lift up on the Pedestal Pin Knob and turn it around. This will cause the angle of the Pedestal Pin to reverse allowing the Table to travel back over the Stop Collars. There are Locking Pins on the Pedestal Pin that fit into a groove on the Pedestal keeping it locked into a direction.

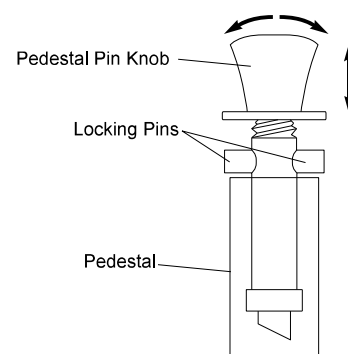
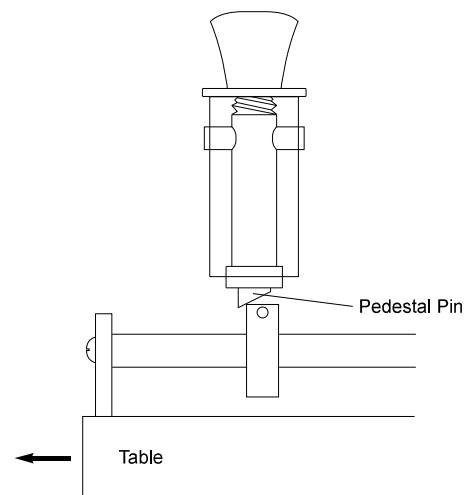

# Operating Instructions

## Drilling Procedures

**Step #12** ■ After all your adjustments are made as desired, position the Table in its original position. Set the product to be drilled on the table and make sure it is secure using the Paper Side Stops. To drill, step down on the Foot Treadle raising the Table up to meet the drill bits. Using one consistent smooth stroke, put pressure on the Treadle so that the Table rises fully allowing the drill bits to drill through the product. It is important you maintain a consistent speed through the entire stack. It is also important you do not go too slow or too fast. If you drill too slow you can burn the paper leaving undesired marks. If you drill too fast, the drill bits will act more like a punch and they will break.

**Note:** Different product requires different speeds. It is always recommended to drill through a test stack of the product until the operator is confident of the required speed.

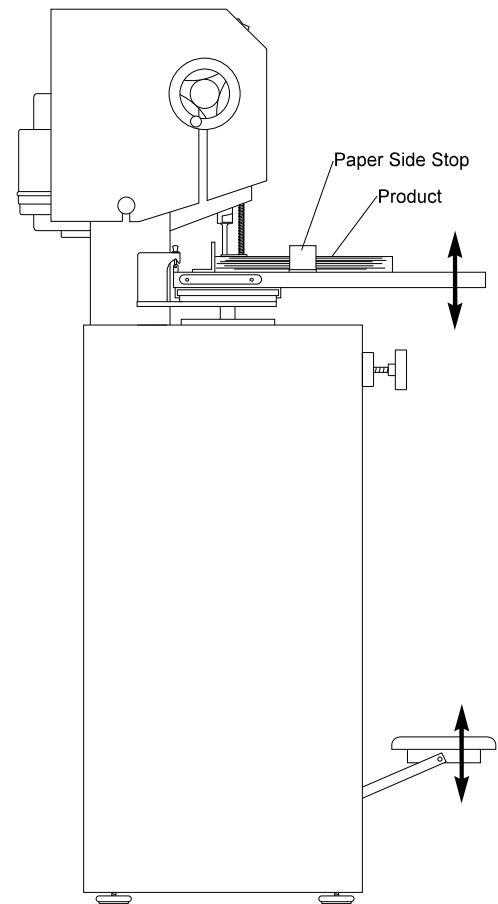

## Tips On Drilling

- **Use a sharp bit at all times...**Using a drill bit sharpener (Lassco-Wizer MS-1 recommended), sharpen your drill bits regularly. Apply light pressure when sharpening. Too much pressure may cause flaring of the tip. (Once a drill bit has a flared tip, it becomes defective.)
- **Sharpening Stone...**Use to debur the outside cutting edge of the drill bits for better performance.
- **Lubricate drill bits occasionally...**use Drill-Ease or Spin-Eze™. While the drill is running, simply touch the Drill-Ease stick to the drill bit or brush on the Spin-Eze™. Drill through scrap to remove any excess. This will allow for a smoother cut.
- **Drill Strips...**When drilling, a drill bit must stop slightly above the drill strip. Replace worn out drill strips regularly to ensure proper drilling.

# Maintenance

**Every 12 Months (or as needed depending on use)**

- **Make sure to unplug the machine from the power supply before conducting any maintenance.**

- Remove the Table by loosening the left end Stop Collar on the Stop Bar Assembly and rotating the Table Traverse Stop down to clear the Pedestal. Pull the Table to the right until the Table clears the slide beneath the Table. Inspect the slide for build-up and lubricate with light machine oil. Using the Foot Treadle raise the Slide and Lubricate the bars underneath the Slide as shown. Replace the Table in the same manner as it was removed and check the Table traverse for free travel.

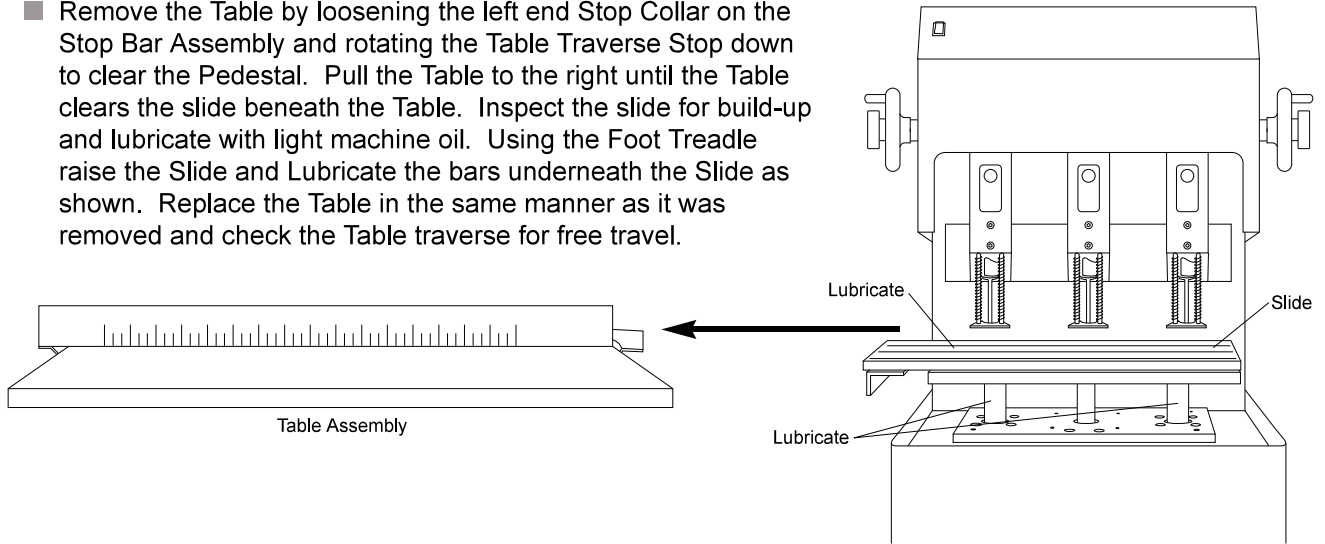

- Lubricate the Stop Pin with light machine oil, work the pin up and down and rotate it a few times for proper lubrication.

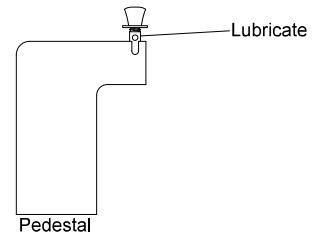

- Lubricate the pivot points, shown in the diagram, in the lower back portion of the machine with light machine oil. Lubricate the Treadle Pivot Assembly at the front of the machine in the same manner.

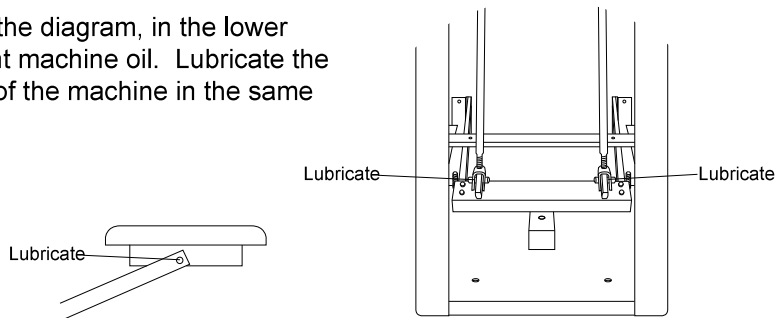

- **Making sure the machine is unplugged** and after disconnecting the electrical wiring to the Switch on the shroud, remove the shroud by lifting straight up to clear the drive mechanism making sure the Traverse Locks are disengaged. Lubricate the two (2) Idler Pulleys with a good grade of grease. A grease gun is required (not included). Rotate the belts by hand to check the Idler Pulleys for wear

**Note:** Some play between the Idler Pulley Bearings and the Idler Pins comply with original specifications and is not a problem.

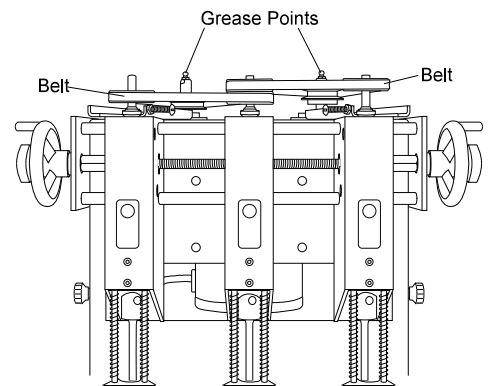

# Maintenance

## Every 12 Months (or as needed depending on use)

- Lubricate the Head Traverse Screws by applying light grease either by hand, or a small brush to the points indicated in the diagram. Move the heads to both extremes to coat the complete surface of the screws and inspect them for thread wear.

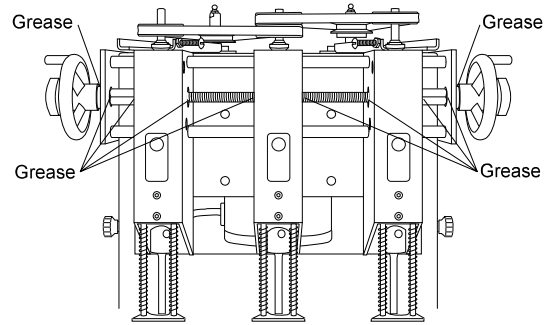

- Apply a light grease on the two (2) Traverse Rods either by hand or with a small brush to the points indicated in the diagram. Crank both heads in and out to distribute the lubrication and to check the head movement.

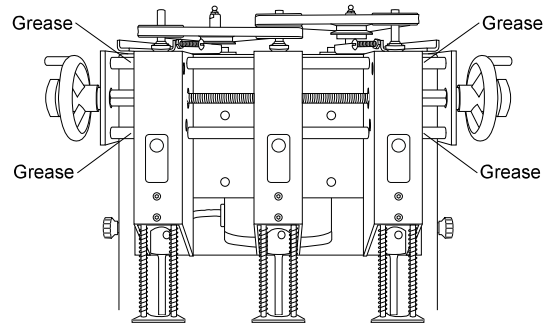

- Inspect the Belts for wear and the proper tension. The tension should be adjusted to an approximate 1/2" gap between a straight edge placed from the outside edge of the Idler Pulley to the outside edge of the Outside Pulley with the pulleys located one behind the other. Depress the belt halfway between the two pulleys and measure the distance between the straight edge and the belt depression.

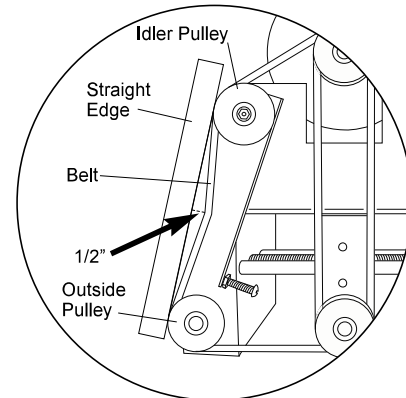

**Belt Tension**

- The belts can be adjusted by loosening the Lock Nut on the Belt Adjustment Screw located on the front portion of the Flex Drive Pivot Assembly and turning the screw clockwise to tighten the belt and counterclockwise to loosen the belt. After the belt has been properly adjusted, re-tighten the Lock Nut.

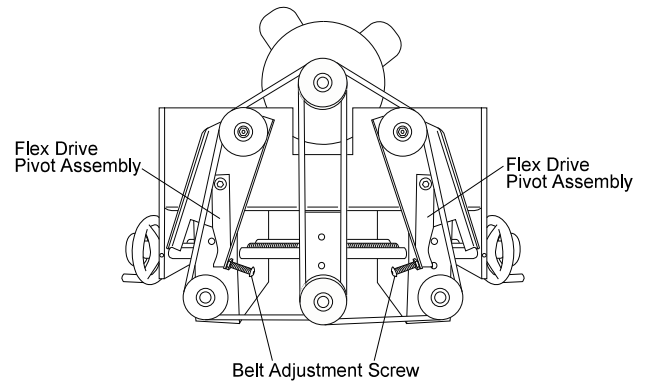

# Maintenance

## Every 12 Months (or as needed depending on use)

- Visually check the Flex Drive Pivot Assembly for unusual wear. Check the Pivot Assembly bolts and tighten if necessary.

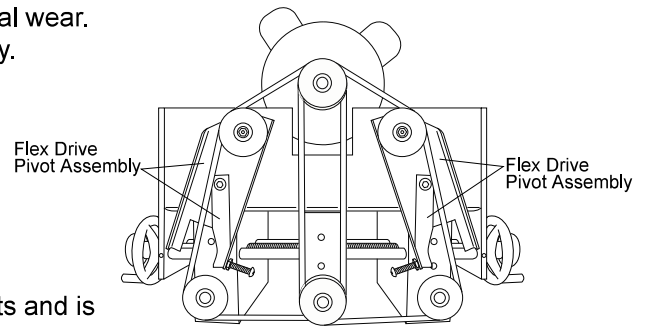

**Note:** Be sure the wiring is clear of all moving components and is properly attached when replacing the Shroud.

- Press down on the Foot Treadle to Raise the Table. Manually holding the Table in place, slowly let up on the Foot Treadle so that the Push Rods in the rear of the machine fall out of the Pin Housings.
- Lubricate the tips of the Push Rods and while holding up the Table return the Push Rods into the Pin Housings. Release the Table so that the Push Rods are locked in place.
- Push down on the Foot Treadle to check for freedom of Travel.

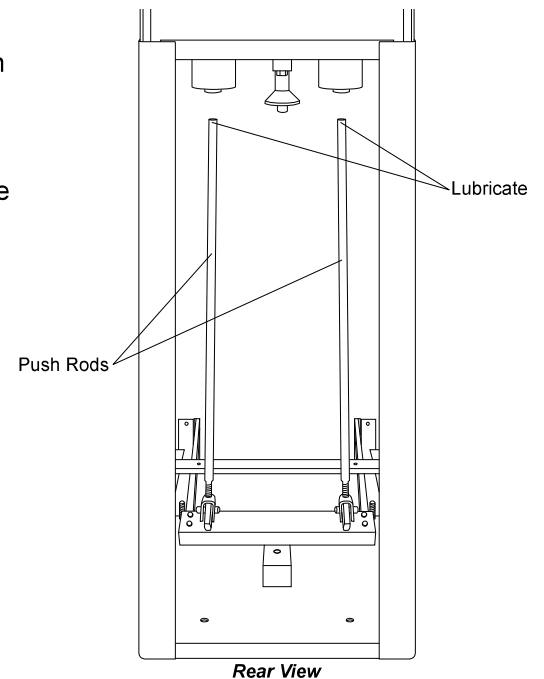

**CAUTION: KEEP FINGERS FROM BETWEEN LIFT COMPONENTS.**

**OBSERVE ALL SAFETY PRECAUTIONS DURING THE PREVENTATIVE MAINTENANCE OF THIS MACHINE.**

# Trouble Shooting Guide

<b>Problem</b>	<b>Cause</b>	<b>Correction</b>
Drill bit not concentric.	Foreign material in chuck or in drill plug.	Inspect and clean.
	Drill bit is bent.	Replace drill bit.
	Drill bit not seated in chuck properly.	Re-insert drill bit correctly. (See <i>Operating Instructions</i> )
	Chuck is not tight to spindle.	Tighten set screw.
Drill bit not drilling.	Drill bit plugged.	Remove and clear chips. Check for other foreign matter.
	Drill bit dull.	Sharpen drill bit.
	<b>Note:</b> In extreme conditions, the drill chuck and/or chip chute may be plugged. Remove the drill bit, loosen the chip chute, pull down, and clean. See <i>Operating Instructions</i>	
Traverse table drags or skips during operation.	Spring Plungers on the Slide Plate are out of adjustment or damaged.	Adjust or replace the Spring Plungers.
	Table traverse channel and/or slide is dirty or needs lubrication.	Clean the channel and lubricate.
	The Table is damaged.	Repair or replace the Table.
	<b>Note:</b> In order to maintain smooth table operation, <b>DO NOT</b> sit on, lean on, or force the table out of alignment.	
Table lift system lifts unevenly or is noisy.	Loose or missing pivot components in the Treadle Pivot Assembly.	Tighten or replace as necessary.
	Push Rods out of adjustment.	Adjust Push Rods to lift evenly.
	Bushings in the lift system are dry or worn.	Lubricate or replace.
	Push Rods are bent.	Replace
	<b>Note:</b> If the raising mechanism is lifted without depressing the Foot Treadle, the Push Rods will drop out of position and must be re-installed in the Pushpins in order to operate the Table.	

# Trouble Shooting Guide

<b>Problem</b>	<b>Cause</b>	<b>Correction</b>
Machine vibrates, wobbles, resonates, etc.	The machine is not level on the floor.	Use the leveling feet to make the machine level on the floor. See <i>Setting Up Your Machine</i> .
	The machine is located directly on a concrete floor.	Place a rubber mat or carpet under the machine.
	Drill bit(s) are not concentric.	Re-install drill bit(s) until they are concentric. See <i>Operating Instructions</i> .
The drill bit(s) are drilling into the drill strip or they are not drilling through the bottom sheet of the product you are drilling.	Drill bit(s) are not adjusted properly to the card stock/card stock not used.	Adjust your drill bit(s) per <i>Operating Instructions</i> .
	The Chuck(s) were not tightened after adjustment.	Re-adjust and tighten.
	The Table Travel Stop is out of adjustment.	Adjust to the proper Table Travel. See <i>Operating Instructions</i> .
The outside Heads are difficult to adjust.	The Lead Screw and/or Traverse Rods are dry or damaged.	Lubricate per <i>Maintenance</i> schedule. Check for damaged or worn components.
	The Hand Wheel Lock is tightend down in place.	Loosen the Hand Wheel Lock enough so the Hand Wheel can be turned.
	An obstruction is between the traversing heads.	Check and remove the obstruction.
The drill bit(s) do not rotate when the motor is turned on.	A Drive Belt is broken on the Flexible Drive System.	Replace the broken belt. See <i>Maintenance</i> .
	A Drive Belt is loose on the Flexible Drive System.	Tighten the loose belt. See <i>Maintenance</i> .
	An Insert Retainer Screw is hitting the inside of the Chuck Housing.	Adjust the Chuck and tighten the Insert Retainer Screw.

# Trouble Shooting Guide

Problem	Cause	Correction
Uncommon metallic sounds from under the shroud.	The Drive Pulley is loose.	Adjust the Drive Pulley to the proper height and tighten or replace the Set Screw.
	The Needle Bearings on the Idler Pulley(s) are not lubricated.	Lubricate the Needle Bearings as needed.
The Chuck cannot be adjusted according to the <i>Operating Instructions</i> .	The Chuck has been adjusted too far down causing the adjustment threads to be disengaged.	Re-adjust to a lower position which may require you to use new hollow drill bits.
	The Chuck has been rotated while in the down position.	Push up on the Chuck and rotate slowly while holding the Spindle stationary until the Chuck returns into a locked position.
	<p><b>Note:</b> The Chuck adjustment is designed for a 1/4" total movement up and down. Once you have sharpened the drill bit down more than a 1/4" from its original length you must replace it. Any drill bits that are longer than approx 2-1/4" or shorter than approx 2" may cause Chuck adjustment problems.</p>	

# Parts Diagrams

## Side View

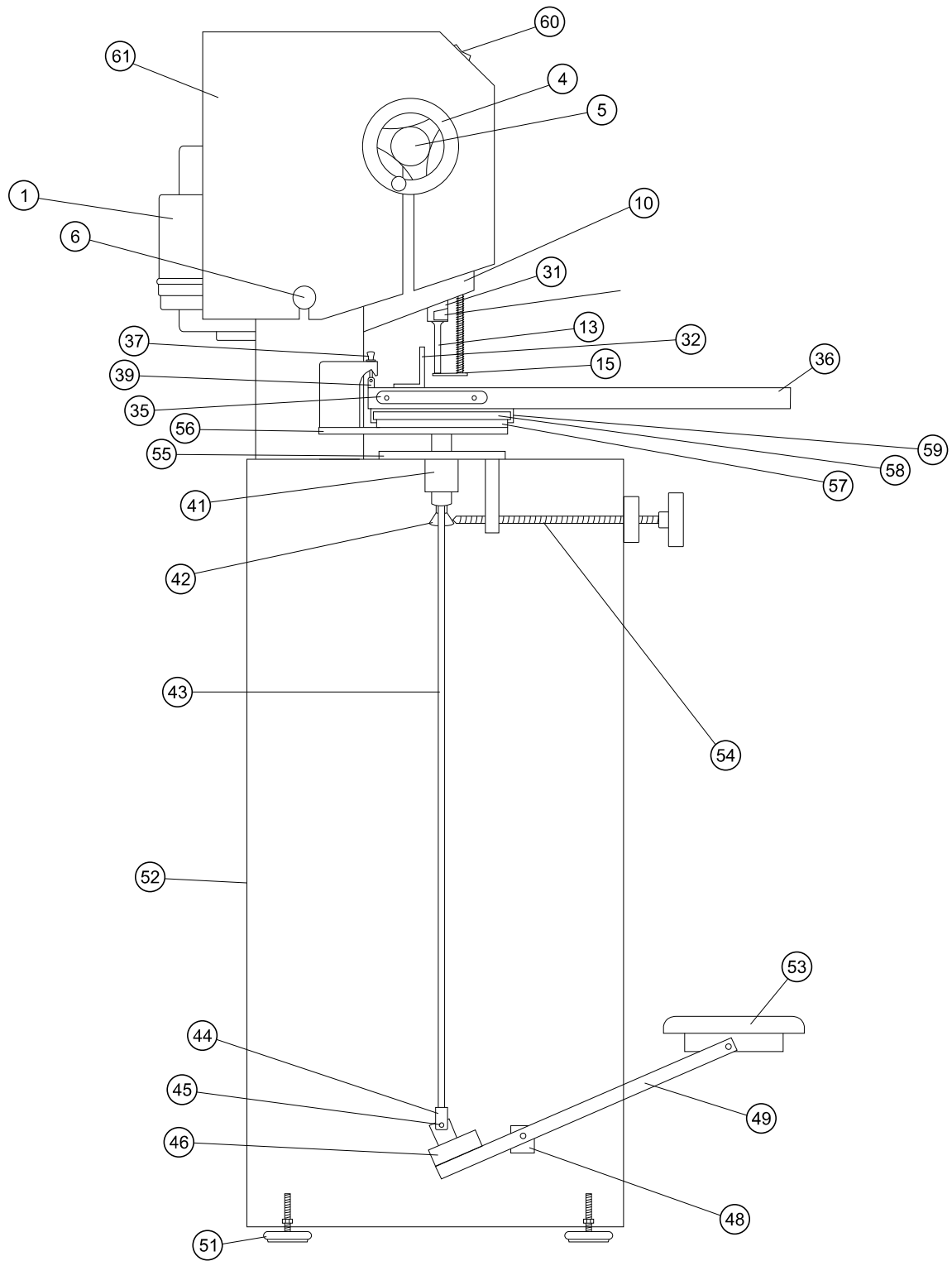

See Parts List on Page 23

# Parts Diagrams

## Head Assembly

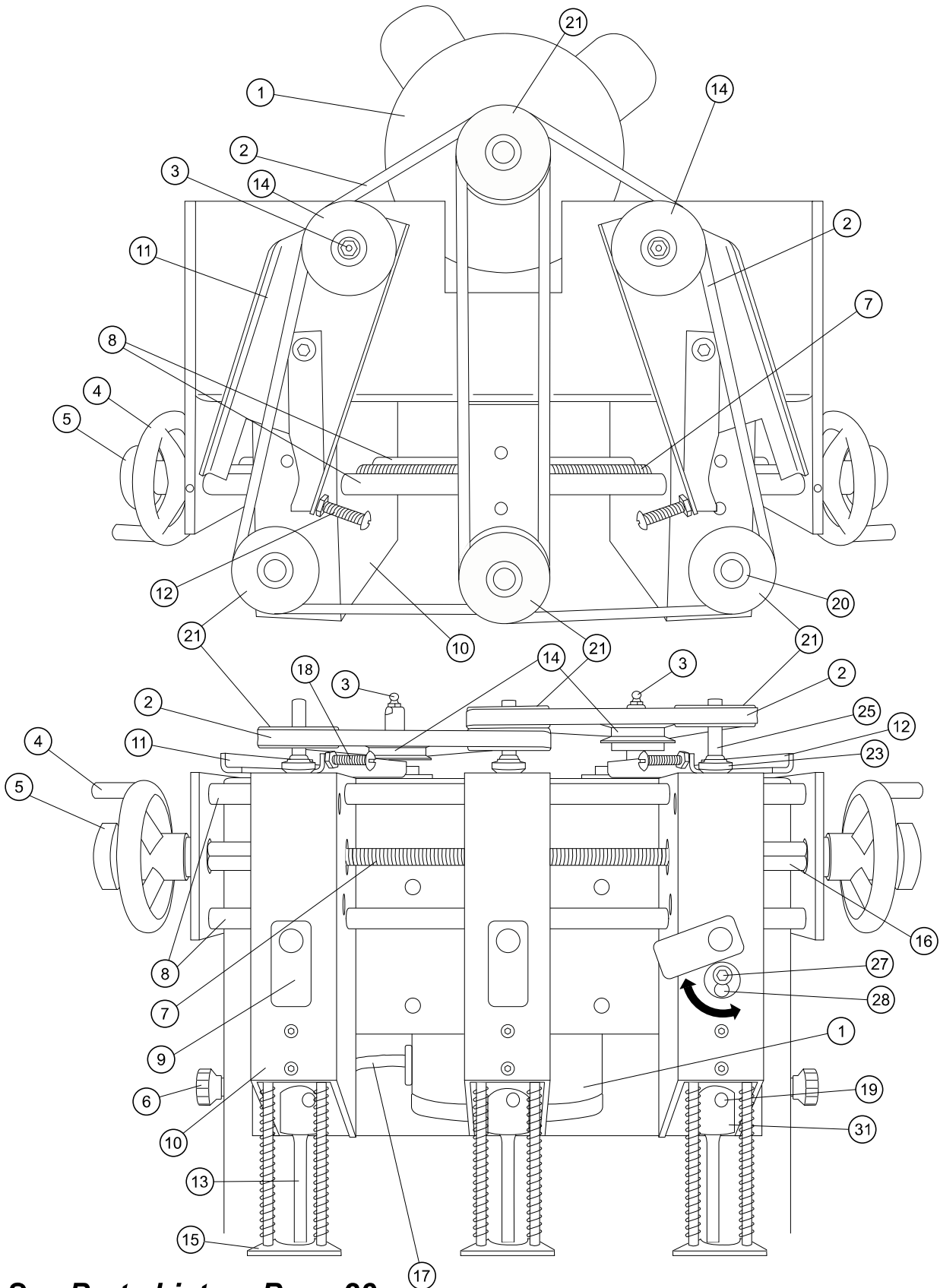

See Parts List on Page 23

# Parts Diagrams

## Spindle And Chuck Assembly

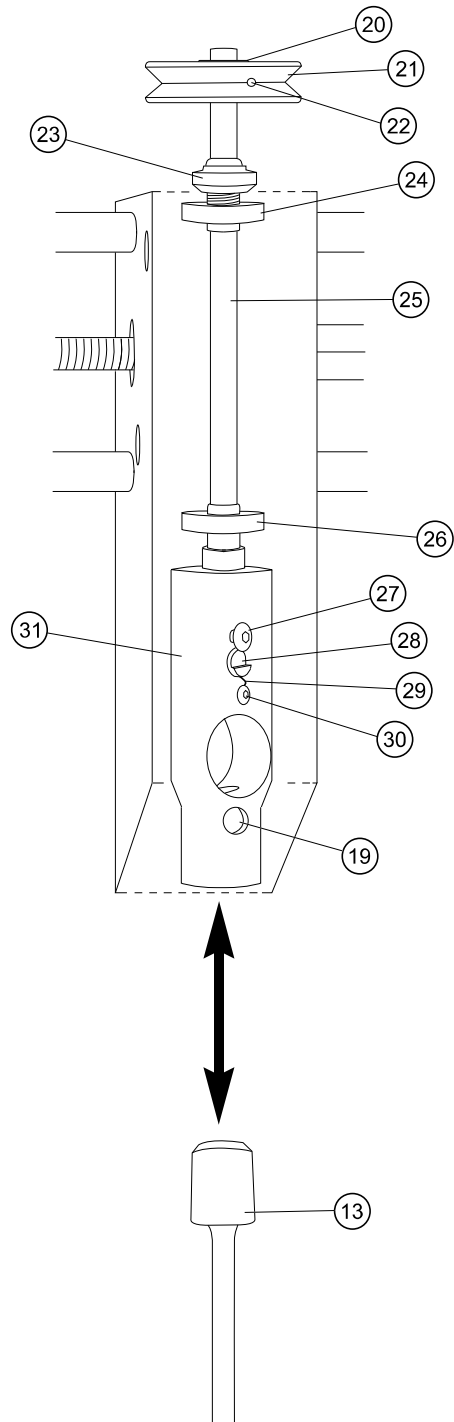

See Parts List on Page 23

# Parts Diagrams

## Rear View

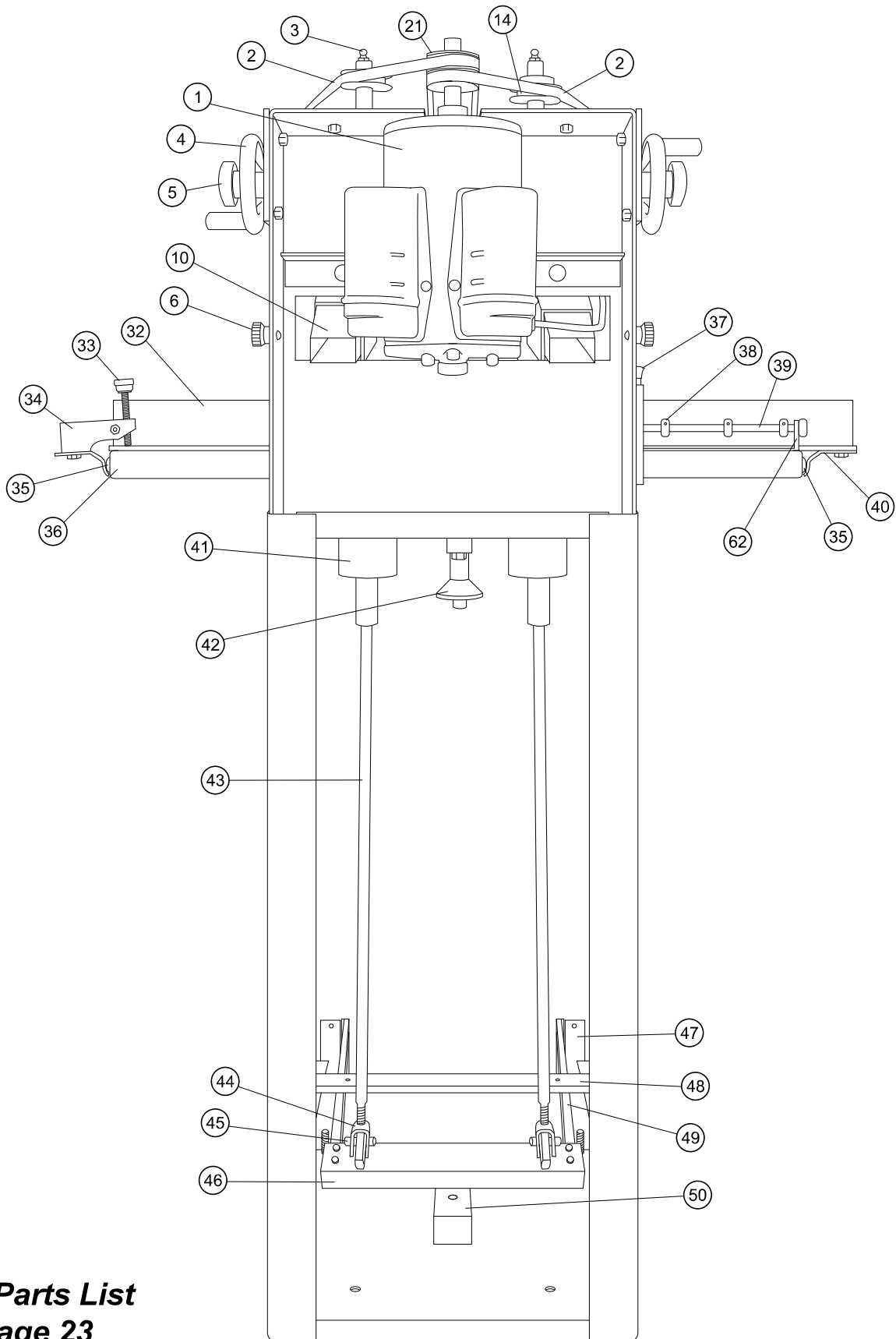

**See Parts List  
on Page 23**

# Parts Diagrams

## Parts List

- ① FMM9-9534: Motor
- ② FMM9-9530: Drive Belt
- ③ Grease Fitting
- ④ FMM8-8504: Hand Wheel
- ⑤ EBM2-1022: Vertical Stop Knob (Lock Knob)
- ⑥ FMM9-9517: Shroud Locking Knob
- ⑦ FMM8-8503: Traverse Lead Screw
- ⑧ FMM8-8502: Traverse Rods
- ⑨ FMM5-5512: Access Cover
- ⑩ FMM5-5506: Housing
- ⑪ FMM9-9500: Left Pivot Channel
- ⑫ FMM9-9502: Right Pivot Channel
- ⑬ Misc: Hollow Drill Bit
- ⑭ FMM9-9505: Idler Pulley
- ⑮ FM6-600A: Pressure Foot Assembly
- ⑯ FMM8-8508: Traverse Stop
- ⑰ FMM9-9516: Cord Set
- ⑱ Cam Adjustment Screw (Belt Adjustment)
- ⑲ Chuck Release Hole
- ⑳ FMM9-9514: Pulley Bushing
- ㉑ FMM9-9506: Pulley
- ㉒ 1/4 x 20 x 3/8 Socket Set Screw
- ㉓ FMM5-5503: Bearing Nut
- ㉔ FMM5-5501: Top Bearing
- ㉕ FMM5-5513: Spindle
- ㉖ FMM5-5502: Bottom Bearing
- ㉗ FMM5-5517: Insert Retainer Screw
- ㉘ FMM5-5515: Insert
- ㉙ FMM5-5516: Spring
- ㉚ FMM5-5518: Spring Retainer Screw
- ㉛ FMM5-5514: Chuck
- ㉜ FM7-70A: Back Gauge Assembly
- ㉝ FM7-7005: Backgauge Knob
- ㉞ FM7-7003: Clamp Bar
- ㉟ FM4-4003: Side Iron
- ㊱ FM4-4000: Table
- ㊲ FM4-401A: Pedestal Stop Assembly
- ㊳ EBM-47: Stop Collar
- ㊴ FM4-4014: Stop Collar Rod
- ㊵ FM7-7002: Backgauge Clamping Bracket
- ㊶ FM3-3007: Pin Housing
- ㊷ FM3-304A: Vertical Table Travel Stop Assembly
- ㊸ FM2-2006: Push Rod
- ㊹ FM2-42: Short Clevis
- ㊺ 50-31: Clevis Pin
- ㊻ FM2-201A: Push Rod Angle Assembly
- ㊼ FM-37: Wear Strip
- ㊽ FM2-200A: Pivot Bar Assembly
- ㊾ FM2-2009: Treadle Bar
- ㊿ FM1-1006: Wood Stop
- ① 50-59: Leveling Feet
- ② FM1-1000: Stand
- ③ FM2-2013: Foot Treadle
- ④ FM3-305A: Vertical Stop Adjustment Assembly
- ⑤ FM3-30A: Die Traverse Assembly
- ⑥ EBM2-1032: Pedestal Support Angle
- ⑦ FM3-3016: Slide Plate Support
- ⑧ FM3-3015: Slide Plate
- ⑨ FM4-4008: Traverse Channel
- ⑩ FM5-5006: On/Off Rocker Switch
- ⑪ FMM9-952A: Shroud Assembly
- ⑫ FM4-4016: Table Traverse Stop

